

PolaPak

Polapak Condensing Unit

PPC Ver2.0



Polapak Condensing Units

Polapak condensing unit is a technology and quality driven product using Bitzer reciprocating compressor and Eden G4 condenser. Polapak is primary used in commercial refrigeration application

Features

- Polapak provides value and reliability while reducing operating and maintenance costs
- Polapak uses Eden G4 condenser with the most advance smart circuitry coil technology combined with double sine wave fin maximizing the heat transfer coefficient
- Eden G4 Condensers are highly efficient, reducing the number of fan motors in most models and offer lower operating delta KTD
- Bitzer semi accessible compressor provides reliable and economical operation under severe operating conditions
- Eden Polapak is designed to minimize vibration and offers quiet operation
- Great aesthetic finish with strong touch of sophistication
- Polapak offers a wide range of selection (nominal capacity from 1HP to 60HP)

Nomenclature

P L B 4 E 0 4 . 0 3 3 7 S . 5 1 T . 0 0

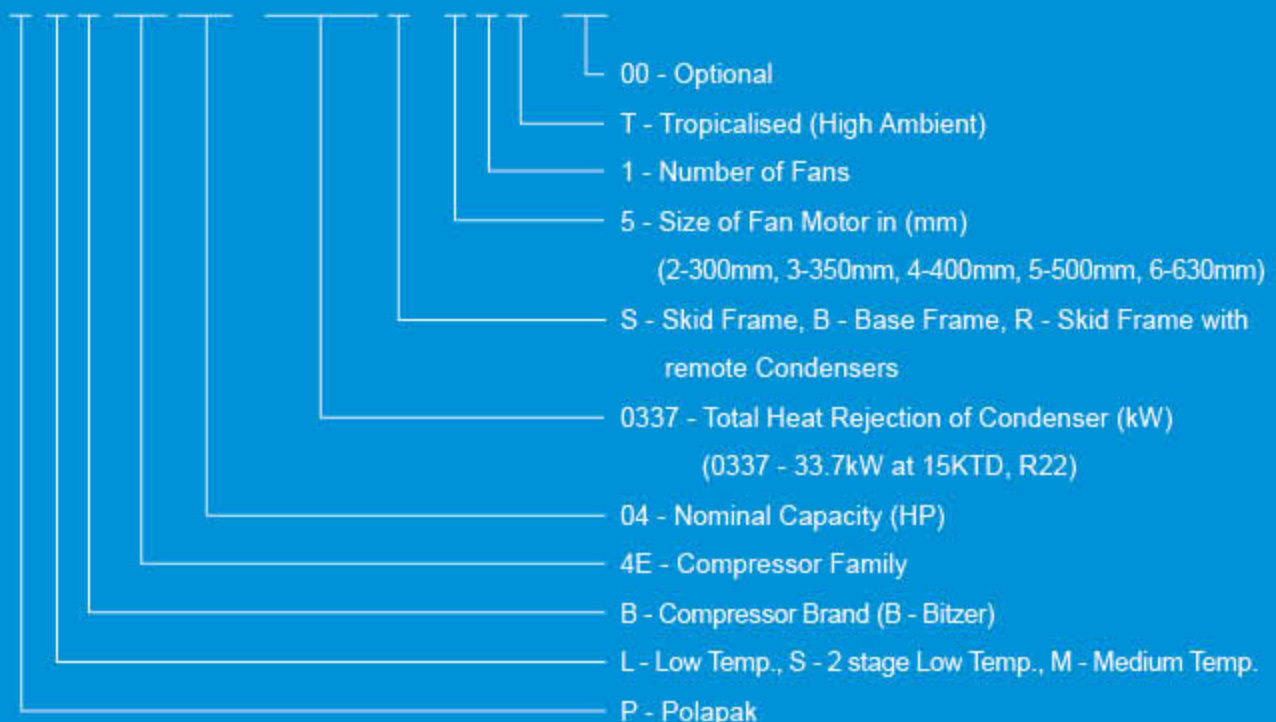

INDEX

Performance Data	2 - 33
Polapak Medium Temperature Series	2 - 19
R134A	2 - 7
R404A/R507A	8 - 13
R22	14 - 19
Polapak Low Temperature Series	20 - 33
R404A/R507A	20 - 26
R22	27 - 33
Technical Data	34 - 35
Dimensions	36 - 38
Accessories Chart	39 - 40
Addition Options	41

POLAPAK Medium Temperature Series
Performance Data
Capacity(kW)

R134A 
50Hz

Compressor Model	Nominal Power (HP)	Ambient Temperature (°C)	SCT (°C)	Refrigerating Capacity Qo(kW) Power Input Pe(kW)							
				Evaporating Temperature (°C)							
				5	0	-5	-10	-15	-20	-25	
PMB2KA5.0054B.21	0.5	35	47	Qo	2.05	1.64	1.28	0.98	0.72	0.50	0.32
				Pe	0.70	0.65	0.59	0.54	0.48	0.41	0.33
		38	50	Qo	1.96	1.57	1.22	0.93	0.68	0.47	0.29
				Pe	0.72	0.67	0.61	0.55	0.49	0.41	0.33
		41	53	Qo	1.88	1.50	1.17	0.89	0.65	0.44	0.27
				Pe	0.75	0.69	0.63	0.57	0.50	0.42	0.33
PMB2KA5.0060B.31T	0.5	35	44	Qo	2.13	1.71	1.34	1.03	0.76	0.53	0.34
				Pe	0.67	0.62	0.58	0.52	0.47	0.40	0.33
		38	47	Qo	2.05	1.64	1.28	0.98	0.72	0.50	0.32
				Pe	0.70	0.65	0.59	0.54	0.48	0.41	0.33
		41	50	Qo	1.96	1.57	1.22	0.93	0.68	0.47	0.29
				Pe	0.72	0.67	0.61	0.55	0.49	0.41	0.33
PMB2JA7.0090B.31	0.7	35	47	Qo	2.62	2.09	1.64	1.25	0.92	0.64	0.41
				Pe	0.90	0.84	0.78	0.70	0.62	0.53	0.42
		38	50	Qo	2.51	2.00	1.57	1.19	0.87	0.60	0.38
				Pe	0.93	0.87	0.80	0.72	0.64	0.53	0.42
		41	53	Qo	2.41	1.92	1.50	1.14	0.83	0.57	0.35
				Pe	0.96	0.90	0.83	0.74	0.65	0.54	0.42
PMB2JA7.0110B.31T	0.7	35	44	Qo	2.73	2.18	1.71	1.31	0.97	0.68	0.44
				Pe	0.88	0.81	0.75	0.69	0.61	0.52	0.42
		38	47	Qo	2.62	2.09	1.64	1.25	0.92	0.64	0.41
				Pe	0.90	0.84	0.78	0.70	0.62	0.53	0.42
		41	50	Qo	2.51	2.00	1.57	1.19	0.87	0.60	0.38
				Pe	0.93	0.87	0.80	0.72	0.64	0.53	0.42
PMB2H02.0090B.31	2	35	47	Qo	3.46	2.81	2.24	1.76	1.35	1.00	0.70
				Pe	1.08	1.03	0.96	0.89	0.81	0.72	0.61
		38	50	Qo	3.32	2.69	2.14	1.67	1.27	0.94	0.65
				Pe	1.12	1.06	0.99	0.91	0.82	0.72	0.61
		41	53	Qo	3.18	2.57	2.04	1.59	1.20	0.88	0.60
				Pe	1.16	1.09	1.02	0.93	0.83	0.72	0.60
PMB2H02.0126B.31T	2	35	44	Qo	3.61	2.93	2.34	1.84	1.42	1.06	0.76
				Pe	1.04	0.99	0.94	0.87	0.79	0.71	0.61
		38	47	Qo	3.46	2.81	2.24	1.76	1.35	1.00	0.70
				Pe	1.08	1.03	0.96	0.89	0.81	0.72	0.61
		41	50	Qo	3.32	2.69	2.14	1.67	1.27	0.94	0.65
				Pe	1.12	1.06	0.99	0.91	0.82	0.72	0.61
PMB2G02.0110B.31	2	35	47	Qo	4.07	3.31	2.66	2.10	1.62	1.22	0.87
				Pe	1.27	1.20	1.12	1.04	0.94	0.83	0.71
		38	50	Qo	3.91	3.18	2.55	2.01	1.54	1.15	0.82
				Pe	1.32	1.24	1.16	1.06	0.95	0.84	0.71
		41	53	Qo	3.75	3.04	2.43	1.91	1.46	1.09	0.77
				Pe	1.36	1.28	1.18	1.08	0.97	0.84	0.71
PMB2G02.0138B.41T	2	35	44	Qo	4.23	3.45	2.77	2.20	1.70	1.28	0.93
				Pe	1.22	1.16	1.09	1.01	0.92	0.82	0.71
		38	47	Qo	4.07	3.31	2.66	2.10	1.62	1.22	0.87
				Pe	1.27	1.20	1.12	1.04	0.94	0.83	0.71
		41	50	Qo	3.91	3.18	2.55	2.01	1.54	1.15	0.82
				Pe	1.32	1.24	1.16	1.06	0.95	0.84	0.71
PMB2F03.0126B.31	3	35	47	Qo	5.04	4.09	3.28	2.58	1.99	1.49	1.07
				Pe	1.62	1.53	1.42	1.31	1.18	1.04	0.89
		38	50	Qo	4.81	3.90	3.12	2.45	1.88	1.40	0.99
				Pe	1.68	1.58	1.46	1.34	1.20	1.05	0.89
		41	53	Qo	4.58	3.71	2.96	2.32	1.77	1.31	0.92
				Pe	1.74	1.62	1.50	1.36	1.21	1.06	0.89

Capacity based on 20°C Suction Temperature with no Sub-Cooling
 Eden cannot guarantee performance of the Condensing Units if non-standard fan motors are used

POLAPAK Medium Temperature Series
Performance Data
Capacity(kW)

R134A 
50Hz

Compressor Model	Nominal Power (HP)	Ambient Temperature (°C)	SCT (°C)	Refrigerating Capacity Qo(kW) Power Input Pe(kW)									
				Evaporating Temperature (°C)									
				5	0	-5	-10	-15	-20	-25			
PMB2F03.0187B.41T	3	35	44	Qo	5.28	4.29	3.44	2.72	2.10	1.58	1.14		
				Pe	1.56	1.48	1.38	1.28	1.16	1.03	0.90		
		38	47	Qo	5.04	4.09	3.28	2.58	1.99	1.49	1.07		
				Pe	1.62	1.53	1.42	1.31	1.18	1.04	0.89		
		41	50	Qo	4.81	3.90	3.12	2.45	1.88	1.40	0.99		
				Pe	1.68	1.58	1.46	1.34	1.20	1.05	0.89		
PMB2E03.0187B.41	3	35	47	Qo	6.36	5.14	4.09	3.20	2.45	1.82	1.30		
				Pe	1.90	1.76	1.61	1.44	1.27	1.10	0.94		
		38	50	Qo	6.07	4.90	3.89	3.04	2.32	1.71	1.21		
				Pe	1.96	1.81	1.64	1.47	1.29	1.11	0.94		
		41	53	Qo	5.78	4.66	3.70	2.88	2.19	1.61	1.13		
				Pe	2.02	1.85	1.67	1.49	1.30	1.11	0.93		
PMB2E03.0227S.51T	3	35	44	Qo	6.65	5.38	4.29	3.36	2.58	1.93	1.38		
				Pe	1.83	1.71	1.57	1.42	1.26	1.10	0.94		
		38	47	Qo	6.36	5.14	4.09	3.20	2.45	1.82	1.30		
				Pe	1.90	1.76	1.61	1.44	1.27	1.10	0.94		
		41	50	Qo	6.07	4.90	3.89	3.04	2.32	1.71	1.21		
				Pe	1.96	1.81	1.64	1.47	1.29	1.11	0.94		
PMB2D03.0227S.51	3	35	47	Qo	7.59	6.15	4.91	3.85	2.96	2.22	1.60		
				Pe	2.25	2.09	1.91	1.72	1.52	1.32	1.12		
		38	50	Qo	7.26	5.87	4.68	3.67	2.81	2.09	1.50		
				Pe	2.34	2.15	1.96	1.75	1.54	1.33	1.12		
		41	53	Qo	6.92	5.59	4.45	3.48	2.66	1.97	1.40		
				Pe	2.41	2.21	2.00	1.77	1.55	1.33	1.12		
PMB2D03.0280S.51T	3	35	44	Qo	7.93	6.43	5.14	4.04	3.12	2.34	1.70		
				Pe	2.17	2.02	1.86	1.68	1.49	1.30	1.12		
		38	47	Qo	7.59	6.15	4.91	3.85	2.96	2.22	1.60		
				Pe	2.25	2.09	1.91	1.72	1.52	1.32	1.12		
		41	50	Qo	7.26	5.87	4.68	3.67	2.81	2.09	1.50		
				Pe	2.34	2.15	1.96	1.75	1.54	1.33	1.12		
PMB2C04.0280S.51	4	35	47	Qo	9.34	7.59	6.08	4.80	3.72	2.81	2.05		
				Pe	2.76	2.57	2.35	2.12	1.89	1.65	1.42		
		38	50	Qo	8.94	7.25	5.81	4.58	3.54	2.67	1.94		
				Pe	2.86	2.65	2.41	2.17	1.92	1.67	1.43		
		41	53	Qo	8.54	6.92	5.54	4.36	3.36	2.52	1.83		
				Pe	2.96	2.72	2.47	2.21	1.94	1.69	1.44		
PMB2C04.0337S.51T	4	35	44	Qo	9.75	7.92	6.36	5.02	3.90	2.96	2.17		
				Pe	2.65	2.48	2.28	2.07	1.85	1.63	1.41		
		38	47	Qo	9.34	7.59	6.08	4.80	3.72	2.81	2.05		
				Pe	2.76	2.57	2.35	2.12	1.89	1.65	1.42		
		41	50	Qo	8.94	7.25	5.81	4.58	3.54	2.67	1.94		
				Pe	2.86	2.65	2.41	2.17	1.92	1.67	1.43		
PMB4F05.0280S.51	5	35	47	Qo	9.92	7.96	6.29	4.90	3.73	2.77	1.99		
				Pe	2.90	2.68	2.43	2.17	1.91	1.65	1.39		
		38	50	Qo	9.44	7.56	5.97	4.63	3.52	2.60	1.85		
				Pe	2.99	2.75	2.48	2.21	1.93	1.65	1.38		
		41	53	Qo	8.96	7.17	5.64	4.36	3.30	2.42	1.70		
				Pe	3.08	2.81	2.53	2.23	1.93	1.64	1.36		
PMB4F05.0376S.51T	5	35	44	Qo	10.40	8.35	6.62	5.16	3.95	2.95	2.14		
				Pe	2.79	2.60	2.37	2.14	1.89	1.64	1.39		
		38	47	Qo	9.92	7.96	6.29	4.90	3.73	2.77	1.99		
				Pe	2.90	2.68	2.43	2.17	1.91	1.65	1.39		
		41	50	Qo	9.44	7.56	5.97	4.63	3.52	2.60	1.85		
				Pe	2.99	2.75	2.48	2.21	1.93	1.65	1.38		

Capacity based on 20°C Suction Temperature with no Sub-Cooling
 Eden cannot guarantee performance of the Condensing Units if non-standard fan motors are used

POLAPAK Medium Temperature Series
Performance Data
Capacity(kW)

R134A 
50Hz

Compressor Model	Nominal Power (HP)	Ambient Temperature (°C)	SCT (°C)		Refrigerating Capacity Qo(kW) Power Input Pe(kW)						
					Evaporating Temperature (°C)						
					5	0	-5	-10	-15	-20	-25
PMB4E06.0337S.51	6	35	47	Qo	12.67	10.30	8.28	6.56	5.12	3.90	2.90
				Pe	3.73	3.46	3.17	2.87	2.55	2.24	1.93
		38	50	Qo	12.11	9.83	7.89	6.24	4.85	3.69	2.73
				Pe	3.87	3.58	3.26	2.93	2.59	2.26	1.94
		41	53	Qo	11.54	9.37	7.51	5.92	4.59	3.47	2.55
				Pe	4.01	3.68	3.34	2.99	2.63	2.28	1.59
PMB4E06.0466S.61T	6	35	44	Qo	13.24	10.78	8.67	6.89	5.38	4.12	3.08
				Pe	3.58	3.34	3.08	2.80	2.50	2.21	1.92
		38	47	Qo	12.67	10.30	8.28	6.56	5.12	3.90	2.90
				Pe	3.73	3.46	3.17	2.87	2.55	2.24	1.93
		41	50	Qo	12.11	9.83	7.89	6.24	4.85	3.69	2.73
				Pe	3.87	3.58	3.26	2.93	2.59	2.26	1.94
PMB4D07.0412S.61	7	35	47	Qo	15.05	12.13	9.85	7.56	5.82	4.39	3.21
				Pe	4.35	4.03	3.67	3.30	2.92	2.53	2.16
		38	50	Qo	14.35	11.55	9.18	7.18	5.51	4.13	3.01
				Pe	4.50	4.15	3.76	3.36	2.95	2.55	2.16
		41	53	Qo	13.66	10.98	8.71	6.79	5.19	3.87	2.80
				Pe	4.65	4.26	3.84	3.41	2.98	2.55	2.15
PMB4D07.0564S.61T	7	35	44	Qo	15.75	12.70	10.12	7.95	6.13	4.64	3.42
				Pe	4.18	3.90	3.57	3.23	2.87	2.51	2.15
		38	47	Qo	15.05	12.13	9.85	7.56	5.82	4.39	3.21
				Pe	4.35	4.03	3.67	3.30	2.92	2.53	2.16
		41	50	Qo	14.35	11.55	9.18	7.18	5.51	4.13	3.01
				Pe	4.50	4.15	3.76	3.36	2.95	2.55	2.16
PMB4C09.0524S.61	9	35	47	Qo	18.52	14.97	11.96	9.43	7.31	5.56	4.13
				Pe	5.35	4.95	4.53	4.07	3.61	3.15	2.71
		38	50	Qo	17.89	14.29	11.40	8.97	6.95	5.27	3.89
				Pe	5.55	5.12	4.65	4.16	3.67	3.19	2.73
		41	53	Qo	16.85	13.60	10.84	8.52	6.57	4.97	3.65
				Pe	5.74	5.26	4.76	4.24	3.72	3.22	2.73
PMB4C09.0760R.52T	9	35	44	Qo	19.35	15.65	12.52	9.88	7.68	5.86	4.37
				Pe	5.13	4.78	4.39	3.98	3.55	3.11	2.69
		38	47	Qo	18.52	14.97	11.96	9.43	7.31	5.56	4.13
				Pe	5.35	4.95	4.53	4.07	3.61	3.15	2.71
		41	50	Qo	17.89	14.29	11.40	8.97	6.95	5.27	3.89
				Pe	5.55	5.12	4.65	4.16	3.67	3.19	2.73
PMB4V10.0524S.61	10	35	47	Qo	19.30	15.49	12.25	9.53	7.26	5.38	3.84
				Pe	5.38	4.98	4.52	4.01	3.48	2.95	2.45
		38	50	Qo	18.37	14.72	11.62	9.02	6.85	5.05	3.59
				Pe	5.56	5.11	4.61	4.07	3.51	2.96	2.44
		41	53	Qo	17.46	13.96	11.00	8.51	6.44	4.73	3.34
				Pe	5.73	5.23	4.69	4.11	3.53	2.96	2.43
PMB4V10.0760R.52T	10	35	44	Qo	20.20	16.26	12.89	10.05	7.68	5.71	4.10
				Pe	5.19	4.84	4.42	3.95	3.45	2.94	2.45
		38	47	Qo	19.30	15.49	12.25	9.53	7.26	5.38	3.84
				Pe	5.38	4.98	4.52	4.01	3.48	2.95	2.45
		41	50	Qo	18.37	14.72	11.62	9.02	6.85	5.05	3.59
				Pe	5.56	5.11	4.61	4.07	3.51	2.96	2.44
PMB4T12.0653R.52	12	35	47	Qo	23.30	18.76	14.90	11.66	8.94	6.69	4.86
				Pe	6.59	6.09	5.53	4.92	4.29	3.68	3.11
		38	50	Qo	22.20	17.86	14.17	11.06	8.46	6.32	4.56
				Pe	6.82	6.27	5.65	5.00	4.35	3.72	3.14
		41	53	Qo	21.10	16.98	13.44	10.47	7.99	5.94	4.28
				Pe	7.04	6.43	5.77	5.08	4.39	3.74	3.15

Capacity based on 20°C Suction Temperature with no Sub-Cooling
 Eden cannot guarantee performance of the Condensing Units if non-standard fan motors are used

POLAPAK Medium Temperature Series
Performance Data
Capacity(kW)

R134A 
50Hz

Compressor Model	Nominal Power (HP)	Ambient Temperature (°C)	SCT (°C)	Refrigerating Capacity Qo(kW) Power Input Pe(kW)							
				Evaporating Temperature (°C)							
				5	0	-5	-10	-15	-20	-25	
PMB4T12.0881R.52T	12	35	44	Qo	24.40	19.66	15.65	12.26	9.43	7.08	5.15
				Pe	6.34	5.91	5.39	4.82	4.23	3.64	3.08
		38	47	Qo	23.30	18.76	14.90	11.66	8.94	6.69	4.86
				Pe	6.59	6.09	5.53	4.92	4.29	3.68	3.11
		41	50	Qo	22.20	17.86	14.17	11.06	8.46	6.32	4.56
				Pe	6.82	6.27	5.65	5.00	4.35	3.72	3.14
PMB4P15.0760R.52	15	35	47	Qo	26.70	21.40	16.87	13.07	9.91	7.29	5.15
				Pe	7.47	6.89	6.22	5.50	4.75	4.01	3.32
		38	50	Qo	25.40	20.30	15.98	12.35	9.32	6.82	4.79
				Pe	7.72	7.07	6.34	5.57	4.78	4.02	3.31
		41	53	Qo	24.10	19.22	15.09	11.62	8.74	6.36	4.43
				Pe	7.95	7.23	6.45	5.63	4.80	4.01	3.28
PMB4P15.1038R.53T	15	35	44	Qo	28.00	22.50	17.77	13.81	10.50	7.76	5.52
				Pe	7.19	6.69	6.08	5.41	4.71	4.00	3.33
		38	47	Qo	26.70	21.40	16.87	13.07	9.91	7.29	5.15
				Pe	7.47	6.89	6.22	5.50	4.75	4.01	3.32
		41	50	Qo	25.40	20.30	15.98	12.35	9.32	6.82	4.79
				Pe	7.72	7.07	6.34	5.57	4.78	4.02	3.31
PMB4N20.0881R.52	20	35	47	Qo	31.80	25.60	20.30	15.92	12.22	9.16	6.66
				Pe	8.91	8.25	7.49	6.67	5.82	4.99	4.21
		38	50	Qo	30.30	24.40	19.34	15.11	11.57	8.65	6.26
				Pe	9.23	8.49	7.66	6.78	5.89	5.02	4.22
		41	53	Qo	28.80	23.20	18.35	14.30	10.93	8.14	5.87
				Pe	9.53	8.71	7.81	6.87	5.94	5.04	4.23
PMB4N20.1158R.53T	20	35	44	Qo	33.20	26.80	21.30	16.74	12.88	9.68	7.06
				Pe	8.57	7.99	7.30	6.54	5.74	4.94	4.19
		38	47	Qo	31.80	25.60	20.30	15.92	12.22	9.16	6.66
				Pe	8.91	8.25	7.49	6.67	5.82	4.99	4.21
		41	50	Qo	30.30	24.40	19.34	15.11	11.57	8.65	6.26
				Pe	9.23	8.49	7.66	6.78	5.89	5.02	4.22
PMB4J22.1038R.53	22	35	47	Qo	35.70	29.00	23.20	18.20	13.99	10.43	7.46
				Pe	9.79	9.13	8.37	7.54	6.67	5.77	4.89
		38	50	Qo	34.10	27.60	22.00	17.27	13.22	9.80	6.94
				Pe	10.16	9.43	8.60	7.70	6.77	5.82	4.89
		41	53	Qo	32.50	26.30	20.90	16.33	12.44	9.16	6.42
				Pe	10.52	9.70	8.80	7.84	6.85	5.85	4.87
PMB4J22.1268R.54T	22	35	44	Qo	37.40	30.30	24.30	19.13	14.76	11.07	7.98
				Pe	9.39	8.82	8.13	7.36	6.54	5.70	4.87
		38	47	Qo	35.70	29.00	23.20	18.20	13.99	10.43	7.46
				Pe	9.79	9.13	8.37	7.54	6.67	5.77	4.89
		41	50	Qo	34.10	27.60	22.00	17.27	13.22	9.80	6.94
				Pe	10.16	9.43	8.60	7.70	6.77	5.82	4.89
PMB4H25.1088R.53	25	35	47	Qo	42.50	34.50	27.70	21.80	16.87	12.70	9.22
				Pe	11.63	10.85	9.98	9.02	8.02	7.00	5.97
		38	50	Qo	40.60	32.90	26.40	20.80	15.99	11.98	8.62
				Pe	12.06	11.20	10.24	9.22	8.15	7.06	5.99
		41	53	Qo	38.70	31.40	25.10	19.68	15.11	11.25	8.01
				Pe	12.47	11.53	10.49	9.39	8.26	7.11	5.97
PMB4H25.1540R.54T	25	35	44	Qo	44.40	36.10	28.90	22.90	17.74	13.42	9.81
				Pe	11.17	10.48	9.69	8.81	7.87	6.90	5.93
		38	47	Qo	42.50	34.50	27.70	21.80	16.87	12.70	9.22
				Pe	11.63	10.85	9.98	9.02	8.02	7.00	5.97
		41	50	Qo	40.60	32.90	26.40	20.80	15.99	11.98	8.62
				Pe	12.06	11.20	10.24	9.22	8.15	7.06	5.99

Capacity based on 20°C Suction Temperature with no Sub-Cooling
 Eden cannot guarantee performance of the Condensing Units if non-standard fan motors are used

POLAPAK Medium Temperature Series
Performance Data
Capacity(kW)

R134A 
50Hz

Compressor Model	Nominal Power (HP)	Ambient Temperature (°C)	SCT (°C)	Refrigerating Capacity Qo(kW) Power Input Pe(kW)							
				Evaporating Temperature (°C)							
				5	0	-5	-10	-15	-20	-25	
PMB4G30.1260R.53	30	35	47	Qo	49.50	40.30	32.30	25.50	19.78	14.95	10.93
				Pe	13.57	12.64	11.60	10.48	9.30	8.08	6.84
		38	50	Qo	47.40	38.50	30.80	24.30	18.77	14.12	10.23
				Pe	14.05	13.02	11.89	10.69	9.43	8.14	6.83
		41	53	Qo	45.20	36.70	29.30	23.10	17.75	13.27	9.51
				Pe	14.51	13.38	12.16	10.87	9.54	8.17	6.80
PMB4G30.1707R.53T	30	35	44	Qo	51.70	42.10	33.80	26.70	20.80	15.77	11.61
				Pe	13.07	12.23	11.29	10.25	9.15	8.00	6.82
		38	47	Qo	49.50	40.30	32.30	25.50	19.78	14.95	10.93
				Pe	13.57	12.64	11.60	10.48	9.30	8.08	6.84
		41	50	Qo	47.40	38.50	30.80	24.30	18.77	14.12	10.23
				Pe	14.05	13.02	11.89	10.69	9.43	8.14	6.83
PMB4F35.1540R.54	35	35	47	Qo	58.10	47.20	38.00	30.10	23.50	17.99	13.43
				Pe	16.85	15.49	14.01	12.47	10.92	9.40	7.95
		38	50	Qo	55.60	45.20	36.30	28.70	22.40	17.06	12.67
				Pe	17.45	15.96	14.37	12.73	11.09	9.49	7.98
		41	53	Qo	53.10	43.10	34.60	27.30	21.20	16.13	11.91
				Pe	18.02	16.40	14.70	12.96	11.23	9.56	8.00
PMB4F35.2030R.63T	35	35	44	Qo	60.60	49.30	39.70	31.50	24.70	18.92	14.18
				Pe	16.21	14.98	13.63	12.19	10.73	9.29	7.91
		38	47	Qo	58.10	47.20	38.00	30.10	23.50	17.99	13.43
				Pe	16.85	15.49	14.01	12.47	10.92	9.40	7.95
		41	50	Qo	55.60	45.20	36.30	28.70	22.40	17.06	12.67
				Pe	17.45	15.96	14.37	12.73	11.09	9.49	7.98
PMB6J33.1385R.54	33	35	47	Qo	54.30	43.90	35.00	27.40	21.10	15.80	11.43
				Pe	14.79	13.76	12.57	11.27	9.90	8.50	7.12
		38	50	Qo	51.80	41.80	33.30	26.00	19.90	14.82	10.62
				Pe	15.34	14.17	12.86	11.46	10.00	8.52	7.08
		41	53	Qo	49.40	39.70	31.50	24.60	18.71	13.84	9.83
				Pe	15.85	14.55	13.13	11.62	10.07	8.52	7.02
PMB6J33.1890R.63T	33	35	44	Qo	56.70	45.90	36.70	28.90	22.30	16.78	12.23
				Pe	14.20	13.31	12.24	11.05	9.77	8.45	7.13
		38	47	Qo	54.30	43.90	35.00	27.40	21.10	15.80	11.43
				Pe	14.79	13.76	12.57	11.27	9.90	8.50	7.12
		41	50	Qo	51.80	41.80	33.30	26.00	19.90	14.82	10.62
				Pe	15.34	14.17	12.86	11.46	10.00	8.52	7.08
PMB6H35.1625R.54	35	35	47	Qo	62.50	50.60	40.50	31.80	24.50	18.46	13.42
				Pe	17.44	16.15	14.70	13.14	11.50	9.86	8.25
		38	50	Qo	59.80	48.30	38.50	30.20	23.20	17.37	12.52
				Pe	18.09	16.65	15.06	13.38	11.64	9.91	8.22
		41	53	Qo	57.00	46.00	36.60	28.60	21.90	16.27	11.63
				Pe	18.70	17.11	15.39	13.85	11.74	9.93	8.18
PMB6H35.2254R.64T	35	35	44	Qo	65.20	52.90	42.40	33.40	25.90	19.55	14.31
				Pe	16.74	15.62	14.31	12.86	11.34	9.78	8.25
		38	47	Qo	62.50	50.60	40.50	31.80	24.50	18.46	13.42
				Pe	17.44	16.15	14.70	13.14	11.50	9.86	8.25
		41	50	Qo	59.80	48.30	38.50	30.20	23.20	17.37	12.52
				Pe	18.09	16.65	15.06	13.38	11.64	9.91	8.22
PMB6G40.1890R.63	40	35	47	Qo	72.40	58.90	47.40	37.60	29.40	22.40	16.59
				Pe	20.80	19.30	17.63	15.85	14.00	12.15	10.36
		38	50	Qo	69.40	56.40	45.40	35.90	27.90	21.20	15.65
				Pe	21.60	19.92	18.11	16.19	14.23	12.29	10.42
		41	53	Qo	66.30	53.90	43.30	34.20	26.50	20.10	14.70
				Pe	22.30	20.50	18.55	16.51	14.44	12.40	10.45

Capacity based on 20°C Suction Temperature with no Sub-Cooling
 Eden cannot guarantee performance of the Condensing Units if non-standard fan motors are used

POLPAK Medium Temperature Series
Performance Data
Capacity(kW)

R134A 
 50Hz

Compressor Model	Nominal Power (HP)	Ambient Temperature (°C)	SCT (°C)	Refrigerating Capacity Qo(kW) Power Input Pe(kW)							
				Evaporating Temperature (°C)							
				5	0	-5	-10	-15	-20	-25	
PMB6G40.2500R.64T	40	35	44	Qo	75.30	61.40	49.50	39.30	30.80	23.50	17.53
				Pe	19.95	18.63	17.12	15.47	13.74	11.99	10.28
		38	47	Qo	72.40	58.90	47.40	37.60	29.40	22.40	16.59
				Pe	20.80	19.30	17.63	15.85	14.00	12.15	10.36
		41	50	Qo	69.40	56.40	45.40	35.90	27.90	21.20	15.65
				Pe	21.60	19.92	18.11	16.19	14.23	12.29	10.42
PMB6F50.2254R.64	50	35	47	Qo	85.70	69.60	55.90	44.20	34.40	26.20	19.41
				Pe	24.80	23.00	21.10	19.01	16.87	14.69	12.53
		38	50	Qo	81.80	66.40	53.20	42.10	32.70	24.80	18.22
				Pe	25.60	23.70	21.60	19.37	17.10	14.81	12.55
		41	53	Qo	77.90	63.20	50.60	39.90	30.90	23.30	17.04
				Pe	26.40	24.30	22.00	19.69	17.30	14.90	12.54
PMB6G60.2650R.64	60	35	47	Qo	99.10	80.50	64.50	50.80	39.10	29.20	-
				Pe	31.00	28.50	25.70	22.80	19.93	17.35	-
		38	50	Qo	94.70	76.80	61.40	48.20	36.90	27.30	-
				Pe	31.90	29.10	26.10	23.00	20.10	17.45	-
		41	53	Qo	90.40	73.20	58.30	45.60	34.80	25.50	-
				Pe	32.80	29.70	26.50	23.20	20.20	17.56	-

Capacity based on 20°C Suction Temperature with no Sub-Cooling
 Eden cannot guarantee performance of the Condensing Units if non-standard fan motors are used

POLAPAK Medium Temperature Series
Performance Data
Capacity(kW)

R404A/R507A 
50Hz

Compressor Model	Nominal Power (HP)	Ambient Temperature (°C)	SCT (°C)	Refrigerating Capacity Qo(kW) Power Input Pe(kW)							
				Evaporating Temperature (°C)							
				5	0	-5	-10	-15	-20	-25	
PMB2KA5.0054B.21	0.5	35	47	Qo	3.02	2.50	2.04	1.64	1.29	0.99	0.73
				Pe	1.07	1.02	0.96	0.90	0.83	0.75	0.66
		38	50	Qo	2.81	2.32	1.89	1.52	1.19	0.91	0.67
				Pe	1.11	1.05	0.99	0.92	0.84	0.76	0.66
		41	53	Qo	2.60	2.15	1.75	1.40	1.09	0.83	0.60
				Pe	1.15	1.09	1.02	0.94	0.86	0.77	0.66
PMB2KA5.0090B.31T	0.5	35	44	Qo	3.23	2.68	2.19	1.77	1.40	1.08	0.81
				Pe	1.02	0.98	0.93	0.87	0.81	0.74	0.65
		38	47	Qo	3.02	2.50	2.04	1.64	1.29	0.99	0.73
				Pe	1.07	1.02	0.96	0.90	0.83	0.75	0.66
		41	50	Qo	2.81	2.32	1.89	1.52	1.19	0.91	0.67
				Pe	1.11	1.05	0.99	0.92	0.84	0.76	0.66
PMB2JA7.0090B.31	0.7	35	47	Qo	4.11	3.42	2.81	2.28	1.81	1.41	1.07
				Pe	1.46	1.39	1.31	1.22	1.12	1.01	0.89
		38	50	Qo	3.85	3.19	2.62	2.12	1.68	1.30	0.98
				Pe	1.53	1.45	1.36	1.26	1.14	1.02	0.89
		41	53	Qo	3.58	2.97	2.43	1.96	1.55	1.19	0.89
				Pe	1.59	1.50	1.40	1.29	1.17	1.04	0.89
PMB2JA7.0110B.31T	0.7	35	44	Qo	4.38	3.64	3.00	2.44	1.95	1.53	1.16
				Pe	1.40	1.34	1.27	1.19	1.10	1.00	0.88
		38	47	Qo	4.11	3.42	2.81	2.28	1.81	1.41	1.07
				Pe	1.46	1.39	1.31	1.22	1.12	1.01	0.89
		41	50	Qo	3.85	3.19	2.62	2.12	1.68	1.30	0.98
				Pe	1.53	1.45	1.36	1.26	1.14	1.02	0.89
PMB2H02.0090B.31	2	35	47	Qo	5.28	4.40	3.62	2.95	2.36	1.85	1.41
				Pe	1.88	1.79	1.68	1.56	1.42	1.27	1.11
		38	50	Qo	4.94	4.11	3.38	2.74	2.19	1.70	1.29
				Pe	1.96	1.85	1.73	1.59	1.44	1.28	1.11
		41	53	Qo	4.60	3.82	3.14	2.54	2.02	1.57	1.18
				Pe	2.03	1.90	1.77	1.62	1.46	1.29	1.11
PMB2H02.0128B.31T	2	35	44	Qo	5.62	4.68	3.86	3.15	2.53	1.99	1.53
				Pe	1.81	1.73	1.63	1.52	1.39	1.26	1.11
		38	47	Qo	5.28	4.40	3.62	2.95	2.36	1.85	1.41
				Pe	1.88	1.79	1.68	1.56	1.42	1.27	1.11
		41	50	Qo	4.94	4.11	3.38	2.74	2.19	1.70	1.29
				Pe	1.96	1.85	1.73	1.59	1.44	1.28	1.11
PMB2G02.0110B.31	2	35	47	Qo	6.02	5.03	4.16	3.40	2.74	2.17	1.68
				Pe	2.23	2.12	1.99	1.84	1.68	1.51	1.34
		38	50	Qo	5.65	4.71	3.89	3.18	2.56	2.02	1.56
				Pe	2.33	2.20	2.05	1.90	1.72	1.54	1.35
		41	53	Qo	5.27	4.39	3.63	2.96	2.37	1.87	1.43
				Pe	2.42	2.28	2.12	1.95	1.76	1.57	1.37
PMB2G02.0138B.41T	2	35	44	Qo	6.40	5.35	4.43	3.63	2.93	2.33	1.81
				Pe	2.13	2.04	1.92	1.79	1.64	1.49	1.32
		38	47	Qo	6.02	5.03	4.16	3.40	2.74	2.17	1.68
				Pe	2.23	2.12	1.99	1.84	1.68	1.51	1.34
		41	50	Qo	5.65	4.71	3.89	3.18	2.56	2.02	1.56
				Pe	2.33	2.20	2.05	1.90	1.72	1.54	1.35
PMB2F03.0128B.31	3	35	47	Qo	7.39	6.17	5.10	4.17	3.37	2.66	2.06
				Pe	2.76	2.61	2.45	2.26	2.06	1.85	1.62
		38	50	Qo	6.89	5.76	4.76	3.89	3.13	2.47	1.90
				Pe	2.88	2.72	2.53	2.33	2.11	1.88	1.64
		41	53	Qo	6.40	5.34	4.41	3.60	2.89	2.27	1.74
				Pe	3.01	2.82	2.62	2.39	2.16	1.91	1.66

Capacity based on 20°C Suction Temperature with no Sub-Cooling
 Eden cannot guarantee performance of the Condensing Units if non-standard fan motors are used

POLAPAK Medium Temperature Series
Performance Data
Capacity(kW)

R404A/R507A 
50Hz

Compressor Model	Nominal Power (HP)	Ambient Temperature (°C)	SCT (°C)	Refrigerating Capacity Qo(kW) Power Input Pe(kW)									
				Evaporating Temperature (°C)									
				5	0	-5	-10	-15	-20	-25			
PMB2F03.0187B.41T	3	35	44	Qo	7.89	6.59	5.46	4.47	3.61	2.86	2.22		
				Pe	2.63	2.51	2.36	2.20	2.01	1.81	1.60		
		38	47	Qo	7.39	6.17	5.10	4.17	3.37	2.66	2.06		
				Pe	2.76	2.61	2.45	2.26	2.06	1.85	1.62		
		41	50	Qo	6.89	5.76	4.76	3.89	3.13	2.47	1.90		
				Pe	2.88	2.72	2.53	2.33	2.11	1.88	1.64		
PMB2E03.0187B.41	3	35	47	Qo	9.62	8.03	6.64	5.43	4.37	3.46	2.67		
				Pe	3.17	2.99	2.79	2.57	2.33	2.08	1.82		
		38	50	Qo	8.98	7.49	6.18	5.04	4.05	3.19	2.45		
				Pe	3.27	3.08	2.86	2.62	2.36	2.09	1.82		
		41	53	Qo	8.33	6.94	5.72	4.66	3.73	2.92	2.23		
				Pe	3.37	3.15	2.91	2.66	2.38	2.10	1.81		
PMB2E03.0227S.51T	3	35	44	Qo	10.25	8.56	7.09	5.80	4.69	3.72	2.89		
				Pe	3.05	2.90	2.72	2.51	2.29	2.06	1.81		
		38	47	Qo	9.62	8.03	6.64	5.43	4.37	3.46	2.67		
				Pe	3.17	2.99	2.79	2.57	2.33	2.08	1.82		
		41	50	Qo	8.98	7.49	6.18	5.04	4.05	3.19	2.45		
				Pe	3.27	3.08	2.86	2.62	2.36	2.09	1.82		
PMB2D03.0227S.51	3	35	47	Qo	11.48	9.60	7.95	6.52	5.27	4.19	3.25		
				Pe	3.83	3.62	3.37	3.10	2.81	2.51	2.20		
		38	50	Qo	10.72	8.96	7.42	6.07	4.89	3.87	2.99		
				Pe	3.97	3.73	3.46	3.17	2.86	2.53	2.21		
		41	53	Qo	9.96	8.31	6.87	5.61	4.51	3.56	2.73		
				Pe	4.09	3.83	3.54	3.22	2.89	2.55	2.21		
PMB2D03.0280S.51T	3	35	44	Qo	12.22	10.22	8.48	6.96	5.64	4.50	3.51		
				Pe	3.68	3.50	3.27	3.03	2.76	2.48	2.18		
		38	47	Qo	11.48	9.60	7.95	6.52	5.27	4.19	3.25		
				Pe	3.83	3.62	3.37	3.10	2.81	2.51	2.20		
		41	50	Qo	10.72	8.96	7.42	6.07	4.89	3.87	2.99		
				Pe	3.97	3.73	3.46	3.17	2.86	2.53	2.21		
PMB2C04.0280S.51	4	35	47	Qo	14.10	11.82	9.83	8.09	6.57	5.25	4.12		
				Pe	4.69	4.44	4.15	3.83	3.49	3.14	2.77		
		38	50	Qo	13.19	11.06	9.18	7.54	6.12	4.88	3.81		
				Pe	4.86	4.58	4.27	3.92	3.56	3.18	2.79		
		41	53	Qo	12.27	10.28	8.53	6.99	5.66	4.50	3.49		
				Pe	5.02	4.72	4.37	4.00	3.62	3.21	2.81		
PMB2C04.0337S.51T	4	35	44	Qo	14.99	12.57	10.46	8.62	7.01	5.62	4.43		
				Pe	4.50	4.28	4.03	3.73	3.42	3.08	2.74		
		38	47	Qo	14.10	11.82	9.83	8.09	6.57	5.25	4.12		
				Pe	4.69	4.44	4.15	3.83	3.49	3.14	2.77		
		41	50	Qo	13.19	11.06	9.18	7.54	6.12	4.88	3.81		
				Pe	4.86	4.58	4.27	3.92	3.56	3.18	2.79		
PMB4F05.0280S.51	5	35	47	Qo	15.44	12.87	10.64	8.72	7.06	5.64	4.44		
				Pe	4.94	4.73	4.46	4.16	3.81	3.44	3.06		
		38	50	Qo	14.40	12.01	9.94	8.13	6.58	5.25	4.13		
				Pe	5.12	4.88	4.58	4.25	3.88	3.49	3.09		
		41	53	Qo	13.35	11.14	9.21	7.54	6.10	4.88	3.81		
				Pe	5.28	5.01	4.69	4.33	3.94	3.53	3.11		
PMB4F05.0376S.51T	5	35	44	Qo	16.46	13.72	11.34	9.29	7.53	6.02	4.74		
				Pe	4.75	4.57	4.33	4.05	3.73	3.39	3.02		
		38	47	Qo	15.44	12.87	10.64	8.72	7.06	5.64	4.44		
				Pe	4.94	4.73	4.46	4.16	3.81	3.44	3.06		
		41	50	Qo	14.40	12.01	9.94	8.13	6.58	5.25	4.13		
				Pe	5.12	4.88	4.58	4.25	3.88	3.49	3.09		

Capacity based on 20°C Suction Temperature with no Sub-Cooling
 Eden cannot guarantee performance of the Condensing Units if non-standard fan motors are used

POLAPAK Medium Temperature Series
Performance Data
Capacity(kW)

R404A/R507A 
50Hz

Compressor Model	Nominal Power (HP)	Ambient Temperature (°C)	SCT (°C)	Refrigerating Capacity Qo(kW) Power Input Pe(kW)							
				Evaporating Temperature (°C)							
				5	0	-5	-10	-15	-20	-25	
PMB4E06.0337S.51	6	35	47	Qo	19.51	16.23	13.39	10.93	8.81	7.01	5.47
				Pe	6.33	6.03	5.66	5.23	4.76	4.26	3.75
		38	50	Qo	18.24	15.17	12.51	10.20	8.22	6.52	5.08
				Pe	6.57	6.22	5.81	5.35	4.85	4.32	3.78
		41	53	Qo	16.95	14.10	11.62	9.47	7.62	6.03	4.68
				Pe	6.79	6.40	5.95	5.45	4.92	4.36	3.79
PMB4E06.0466S.61T	6	35	44	Qo	20.80	17.27	14.25	11.64	9.40	7.49	5.86
				Pe	6.08	5.82	5.49	5.10	4.66	4.19	3.71
		38	47	Qo	19.51	16.23	13.39	10.93	8.81	7.01	5.47
				Pe	6.33	6.03	5.66	5.23	4.76	4.26	3.75
		41	50	Qo	18.24	15.17	12.51	10.20	8.22	6.52	5.08
				Pe	6.57	6.22	5.81	5.35	4.85	4.32	3.78
PMB4D07.0412S.61	7	35	47	Qo	23.60	19.64	16.23	13.27	10.73	8.56	6.72
				Pe	7.54	7.19	6.76	6.27	5.72	5.15	4.55
		38	50	Qo	22.10	18.43	15.22	12.44	10.04	8.00	6.26
				Pe	7.83	7.43	6.96	6.42	5.84	5.23	4.61
		41	53	Qo	20.70	17.21	14.20	11.59	9.34	7.43	5.80
				Pe	8.10	7.65	7.14	6.56	5.95	5.31	4.65
PMB4D07.0564S.61T	7	35	44	Qo	25.00	20.80	17.22	14.10	11.42	9.13	7.18
				Pe	7.24	6.93	6.55	6.10	5.59	5.05	4.49
		38	47	Qo	23.60	19.64	16.23	13.27	10.73	8.56	6.72
				Pe	7.54	7.19	6.76	6.27	5.72	5.15	4.55
		41	50	Qo	22.10	18.43	15.22	12.44	10.04	8.00	6.26
				Pe	7.83	7.43	6.96	6.42	5.84	5.23	4.61
PMB4C09.0524S.61	9	35	47	Qo	28.80	23.90	19.70	16.06	12.94	10.28	8.02
				Pe	9.37	8.88	8.30	7.64	6.93	6.17	5.41
		38	50	Qo	27.10	22.50	18.52	15.08	12.12	9.61	7.48
				Pe	9.75	9.19	8.55	7.83	7.07	6.27	5.47
		41	53	Qo	25.40	21.10	17.33	14.09	11.30	8.93	6.93
				Pe	10.10	9.48	8.78	8.01	7.20	6.36	5.52
PMB4C09.0760R.52T	9	35	44	Qo	30.40	25.30	20.90	17.04	13.76	10.95	8.57
				Pe	8.98	8.56	8.04	7.44	6.77	6.06	5.33
		38	47	Qo	28.80	23.90	19.70	16.06	12.94	10.28	8.02
				Pe	9.37	8.88	8.30	7.64	6.93	6.17	5.41
		41	50	Qo	27.10	22.50	18.52	15.08	12.12	9.61	7.48
				Pe	9.75	9.19	8.55	7.83	7.07	6.27	5.47
PMB4V10.0524S.61	10	35	47	Qo	30.30	25.00	20.40	16.49	13.12	10.25	7.84
				Pe	9.40	8.83	8.16	7.43	6.66	5.86	5.05
		38	50	Qo	28.40	23.40	19.10	15.39	12.21	9.50	7.23
				Pe	9.75	9.10	8.38	7.59	6.77	5.93	5.08
		41	53	Qo	26.50	21.80	17.77	14.28	11.29	8.76	6.63
				Pe	10.08	9.37	8.58	7.74	6.88	5.99	5.11
PMB4V10.0760R.52T	10	35	44	Qo	32.20	26.60	21.80	17.60	14.04	11.01	8.46
				Pe	9.04	8.53	7.93	7.26	6.54	5.78	5.00
		38	47	Qo	30.30	25.00	20.40	16.49	13.12	10.25	7.84
				Pe	9.40	8.83	8.16	7.43	6.66	5.86	5.05
		41	50	Qo	28.40	23.40	19.10	15.39	12.21	9.50	7.23
				Pe	9.75	9.10	8.38	7.59	6.77	5.93	5.08
PMB4T12.0653R.52	12	35	47	Qo	36.60	30.20	24.80	20.10	16.06	12.64	9.75
				Pe	11.54	10.85	10.06	9.18	8.24	7.28	6.30
		38	50	Qo	34.30	28.40	23.20	18.78	14.98	11.75	9.03
				Pe	11.99	11.22	10.35	9.41	8.41	7.39	6.38
		41	53	Qo	32.10	26.50	21.60	17.47	13.90	10.87	8.32
				Pe	12.42	11.57	10.63	9.62	8.57	7.50	6.45

Capacity based on 20°C Suction Temperature with no Sub-Cooling
 Eden cannot guarantee performance of the Condensing Units if non-standard fan motors are used

POLPAK Medium Temperature Series
Performance Data
Capacity(kW)

R404A/R507A 
50Hz

Compressor Model	Nominal Power (HP)	Ambient Temperature (°C)	SCT (°C)	Refrigerating Capacity Qo(kW) Power Input Pe(kW)							
				Evaporating Temperature (°C)							
				5	0	-5	-10	-15	-20	-25	
PMB4T12.0881R.52T	12	35	44	Qo	38.80	32.10	26.40	21.40	17.14	13.53	10.48
				Pe	11.07	10.47	9.75	8.94	8.07	7.15	6.22
		38	47	Qo	36.60	30.20	24.80	20.10	16.06	12.64	9.75
				Pe	11.54	10.85	10.06	9.18	8.24	7.28	6.30
		41	50	Qo	34.30	28.40	23.20	18.78	14.98	11.75	9.03
				Pe	11.99	11.22	10.35	9.41	8.41	7.39	6.38
PMB4P15.0760R.52	15	35	47	Qo	42.00	34.60	28.20	22.70	17.97	13.99	10.64
				Pe	13.17	12.34	11.38	10.32	9.19	8.03	6.87
		38	50	Qo	39.30	32.40	26.30	21.10	16.69	12.94	9.79
				Pe	13.65	12.72	11.67	10.53	9.33	8.11	6.90
		41	53	Qo	36.70	30.10	24.50	19.58	15.42	11.90	8.95
				Pe	14.11	13.08	11.94	10.72	9.46	8.18	6.91
PMB4P15.1038R.53T	15	35	44	Qo	44.60	36.80	30.00	24.20	19.27	15.05	11.50
				Pe	12.66	11.93	11.06	10.09	9.04	7.94	6.83
		38	47	Qo	42.00	34.60	28.20	22.70	17.97	13.99	10.64
				Pe	13.17	12.34	11.38	10.32	9.19	8.03	6.87
		41	50	Qo	39.30	32.40	26.30	21.10	16.69	12.94	9.79
				Pe	13.65	12.72	11.67	10.53	9.33	8.11	6.90
PMB4N20.0861R.52	20	35	47	Qo	49.90	41.30	33.80	27.40	21.90	17.27	13.35
				Pe	15.58	14.66	13.60	12.42	11.16	9.87	8.57
		38	50	Qo	46.80	38.70	31.70	25.60	20.50	16.08	12.38
				Pe	16.19	15.16	13.99	12.72	11.39	10.03	8.67
		41	53	Qo	43.70	36.10	29.50	23.90	19.00	14.88	11.42
				Pe	16.78	15.64	14.37	13.02	11.61	10.88	8.70
PMB4N20.1158R.53T	20	35	44	Qo	52.90	43.80	35.90	29.20	23.40	18.48	14.33
				Pe	14.94	14.14	13.18	12.09	10.92	9.69	8.45
		38	47	Qo	49.90	41.30	33.80	27.40	21.90	17.27	13.35
				Pe	15.58	14.66	13.60	12.42	11.16	9.87	8.57
		41	50	Qo	46.80	38.70	31.70	25.60	20.50	16.08	12.38
				Pe	16.19	15.16	13.99	12.72	11.39	10.03	8.67
PMB4J22.1038R.53	22	35	47	Qo	55.30	46.00	37.90	30.90	24.80	19.55	15.08
				Pe	17.36	16.30	15.12	13.83	12.47	11.05	9.61
		38	50	Qo	51.90	43.20	35.50	28.90	23.10	18.15	13.93
				Pe	18.00	16.82	15.53	14.13	12.67	11.16	9.64
		41	53	Qo	48.60	40.30	33.10	26.90	21.40	16.76	12.78
				Pe	18.61	17.31	15.90	14.40	12.84	11.25	9.66
PMB4J22.1268R.54T	22	35	44	Qo	58.60	48.80	40.30	32.90	26.50	20.90	16.23
				Pe	16.68	15.75	14.68	13.50	12.24	10.91	9.54
		38	47	Qo	55.30	46.00	37.90	30.90	24.80	19.55	15.08
				Pe	17.36	16.30	15.12	13.83	12.47	11.05	9.61
		41	50	Qo	51.90	43.20	35.50	28.90	23.10	18.15	13.93
				Pe	18.00	16.82	15.53	14.13	12.67	11.16	9.64
PMB4H25.1088R.53	25	35	47	Qo	64.70	54.00	44.70	36.80	29.50	23.50	18.35
				Pe	20.50	19.29	17.93	16.45	14.89	13.27	11.62
		38	50	Qo	60.70	50.70	41.90	34.20	27.60	21.90	17.04
				Pe	21.20	19.89	18.41	16.82	15.15	13.44	11.71
		41	53	Qo	56.70	47.30	39.10	31.90	25.70	20.30	15.73
				Pe	21.90	20.40	18.85	17.15	15.38	13.58	11.77
PMB4H25.1540R.54T	25	35	44	Qo	68.50	57.20	47.40	38.90	31.50	25.10	19.66
				Pe	19.72	18.65	17.42	16.06	14.60	13.07	11.51
		38	47	Qo	64.70	54.00	44.70	36.80	29.50	23.50	18.35
				Pe	20.50	19.29	17.93	16.45	14.89	13.27	11.62
		41	50	Qo	60.70	50.70	41.90	34.20	27.60	21.90	17.04
				Pe	21.20	19.89	18.41	16.82	15.15	13.44	11.71

Capacity based on 20°C Suction Temperature with no Sub-Cooling
 Eden cannot guarantee performance of the Condensing Units if non-standard fan motors are used

POLAPAK Medium Temperature Series
Performance Data
Capacity(kW)

R404A/R507A 
50Hz

Compressor Model	Nominal Power (HP)	Ambient Temperature (°C)	SCT (°C)		Refrigerating Capacity Qo(kW) Power Input Pe(kW)						
					Evaporating Temperature (°C)						
					5	0	-5	-10	-15	-20	-25
PMB4G30.1260R.53	30	35	47	Qo	73.90	61.80	51.20	42.00	34.00	27.20	21.30
				Pe	23.70	22.30	20.70	19.01	17.21	15.36	13.47
		38	50	Qo	69.40	57.90	48.00	39.30	31.80	25.30	19.83
				Pe	24.50	22.90	21.20	19.42	17.52	15.56	13.59
		41	53	Qo	64.70	54.00	44.70	36.60	29.60	23.50	18.34
				Pe	25.20	23.50	21.70	19.80	17.79	15.74	13.68
PMB4G30.1707R.53T	30	35	44	Qo	78.40	65.60	54.40	44.70	36.20	29.00	22.80
				Pe	22.80	21.60	20.10	18.56	16.87	15.12	13.33
		38	47	Qo	73.90	61.80	51.20	42.00	34.00	27.20	21.30
				Pe	23.70	22.30	20.70	19.01	17.21	15.36	13.47
		41	50	Qo	69.40	57.90	48.00	39.30	31.80	25.30	19.83
				Pe	24.50	22.90	21.20	19.42	17.52	15.56	13.59
PMB4F35.1540R.54	35	35	47	Qo	87.40	73.50	61.40	50.70	41.40	33.40	26.40
				Pe	29.30	27.70	25.80	23.70	21.50	19.19	16.80
		38	50	Qo	82.00	69.00	57.60	47.60	38.90	31.30	24.70
				Pe	30.40	28.60	26.50	24.30	21.90	19.46	16.95
		41	53	Qo	76.50	64.40	53.80	44.40	36.20	29.10	22.90
				Pe	31.40	29.40	27.20	24.80	22.30	19.69	17.06
PMB4F35.2030R.63T	35	35	44	Qo	92.80	78.00	65.10	53.80	44.00	35.50	28.20
				Pe	28.20	26.80	25.10	23.10	21.10	18.87	16.61
		38	47	Qo	87.40	73.50	61.40	50.70	41.40	33.40	26.40
				Pe	29.30	27.70	25.80	23.70	21.50	19.19	16.80
		41	50	Qo	82.00	69.00	57.60	47.60	38.90	31.30	24.70
				Pe	30.40	28.60	26.50	24.30	21.90	19.46	16.95
PMB6J33.1385R.54	33	35	47	Qo	82.30	68.40	56.30	45.70	36.70	28.90	22.20
				Pe	25.00	23.70	22.10	20.40	18.41	16.34	14.20
		38	50	Qo	77.40	64.30	52.80	42.80	34.20	26.80	20.50
				Pe	25.90	24.40	22.70	20.80	18.70	16.51	14.25
		41	53	Qo	72.50	60.10	49.30	39.90	31.70	24.80	18.84
				Pe	26.80	25.10	23.20	21.20	18.94	16.63	14.26
PMB6J33.1890R.63T	33	35	44	Qo	87.10	72.40	59.70	48.70	39.10	30.90	23.90
				Pe	24.10	22.90	21.50	19.88	18.07	16.13	14.11
		38	47	Qo	82.30	68.40	56.30	45.70	36.70	28.90	22.20
				Pe	25.00	23.70	22.10	20.40	18.41	16.34	14.20
		41	50	Qo	77.40	64.30	52.80	42.80	34.20	26.80	20.50
				Pe	25.90	24.40	22.70	20.80	18.70	16.51	14.25
PMB6H35.1625R.54	35	35	47	Qo	95.00	79.30	65.60	53.80	43.50	34.60	27.00
				Pe	30.10	28.50	26.60	24.60	22.30	19.98	17.55
		38	50	Qo	89.30	74.50	61.60	50.40	40.70	32.30	25.10
				Pe	31.20	29.40	27.40	25.20	22.80	20.30	17.72
		41	53	Qo	83.50	69.70	57.60	47.00	37.80	29.90	23.10
				Pe	32.20	30.30	28.10	25.70	23.20	20.50	17.84
PMB6H35.2254R.64T	35	35	44	Qo	100.60	84.00	69.60	57.10	46.30	36.90	28.90
				Pe	28.90	27.50	25.80	23.90	21.90	19.64	17.34
		38	47	Qo	95.00	79.30	65.60	53.80	43.50	34.60	27.00
				Pe	30.10	28.50	26.60	24.60	22.30	19.98	17.55
		41	50	Qo	89.30	74.50	61.60	50.40	40.70	32.30	25.10
				Pe	31.20	29.40	27.40	25.20	22.80	20.30	17.72
PMB6G40.1890R.63	40	35	47	Qo	107.00	89.70	74.50	61.30	49.80	39.90	31.30
				Pe	34.90	33.00	30.90	28.50	25.90	23.30	20.50
		38	50	Qo	100.40	84.10	69.90	57.40	46.60	37.20	29.10
				Pe	36.10	34.10	31.70	29.20	26.50	23.60	20.70
		41	53	Qo	93.70	78.50	65.10	53.40	43.30	34.50	26.90
				Pe	37.30	35.00	32.50	29.80	26.90	23.90	20.90

Capacity based on 20°C Suction Temperature with no Sub-Cooling
 Eden cannot guarantee performance of the Condensing Units if non-standard fan motors are used

POLPAK Medium Temperature Series
Performance Data
Capacity(kW)

R404A/R507A 
50Hz

Compressor Model	Nominal Power (HP)	Ambient Temperature (°C)	SCT (°C)	Refrigerating Capacity Qo(kW) Power Input Pe(kW)							
				Evaporating Temperature (°C)							
				5	0	-5	-10	-15	-20	-25	
PMB6G40.2500R.64T	40	35	44	Qo	113.60	95.20	79.10	65.10	53.00	42.50	33.50
				Pe	33.60	31.90	30.00	27.80	25.40	22.90	20.30
		38	47	Qo	107.00	89.70	74.50	61.30	49.80	39.90	31.30
				Pe	34.90	33.00	30.90	28.50	25.90	23.30	20.50
		41	50	Qo	100.40	84.10	69.90	57.40	46.60	37.20	29.10
				Pe	36.10	34.10	31.70	29.20	26.50	23.60	20.70
PMB6F50.2254R.64	50	35	47	Qo	129.90	109.00	90.80	74.90	61.00	48.90	38.50
				Pe	43.30	40.90	38.20	35.20	31.90	28.50	25.00
		38	50	Qo	121.70	102.20	85.10	70.10	57.10	45.70	35.90
				Pe	44.80	42.10	39.20	35.90	32.40	28.80	25.10
		41	53	Qo	113.50	95.30	79.40	65.40	53.10	42.40	33.20
				Pe	46.20	43.30	40.00	36.60	32.90	29.10	25.20
PMB6G60.2650R.64	60	35	47	Qo	150.20	126.20	105.20	86.60	70.40	56.10	-
				Pe	54.20	51.10	47.40	43.30	38.90	34.30	-
		38	50	Qo	140.30	117.90	98.20	80.90	65.60	52.20	-
				Pe	55.80	52.40	48.40	44.10	39.40	34.60	-
		41	53	Qo	130.30	109.60	91.30	75.10	60.80	48.30	-
				Pe	57.30	53.50	49.30	44.80	39.90	34.90	-

Capacity based on 20°C Suction Temperature with no Sub-Cooling
 Eden cannot guarantee performance of the Condensing Units if non-standard fan motors are used

POLAPAK Medium Temperature Series
Performance Data
Capacity(kW)



Compressor Model	Nominal Power (HP)	Ambient Temperature (°C)	SCT (°C)	Refrigerating Capacity Qo(kW) Power Input Pe(kW)							
				Evaporating Temperature (°C)							
				5	0	-5	-10	-15	-20	-25	
PMB2KA5.0054B.21	0.5	35	47	Qo	3.31	2.66	2.11	1.66	1.29	0.99	0.74
				Pe	1.11	1.06	0.99	0.90	0.81	0.71	0.60
		38	50	Qo	3.16	2.53	2.01	1.58	1.22	0.93	0.70
				Pe	1.16	1.10	1.02	0.93	0.82	0.72	0.61
		41	53	Qo	3.01	2.41	1.91	1.49	1.15	0.88	0.66
				Pe	1.20	1.13	1.05	0.95	0.84	0.73	0.62
PMB2KA5.0060B.31T	0.5	35	44	Qo	3.46	2.78	2.22	1.75	1.36	1.05	0.79
				Pe	1.07	1.02	0.96	0.88	0.79	0.69	0.59
		38	47	Qo	3.31	2.66	2.11	1.66	1.29	0.99	0.74
				Pe	1.11	1.06	0.99	0.90	0.81	0.71	0.60
		41	50	Qo	3.16	2.53	2.01	1.58	1.22	0.93	0.70
				Pe	1.16	1.10	1.02	0.93	0.82	0.72	0.61
PMB2JA7.0090B.31	0.7	35	47	Qo	4.15	3.41	2.77	2.22	1.76	1.37	1.04
				Pe	1.36	1.29	1.21	1.12	1.02	0.91	0.80
		38	50	Qo	3.97	3.25	2.64	2.11	1.67	1.29	0.98
				Pe	1.42	1.34	1.25	1.16	1.05	0.93	0.81
		41	53	Qo	3.79	3.10	2.51	2.01	1.58	1.22	0.92
				Pe	1.48	1.40	1.30	1.19	1.08	0.95	0.83
PMB2JA7.0110B.31T	0.7	35	44	Qo	4.34	3.56	2.90	2.33	1.85	1.44	1.10
				Pe	1.29	1.23	1.16	1.08	0.99	0.89	0.79
		38	47	Qo	4.15	3.41	2.77	2.22	1.76	1.37	1.04
				Pe	1.36	1.29	1.21	1.12	1.02	0.91	0.80
		41	50	Qo	3.97	3.25	2.64	2.11	1.67	1.29	0.98
				Pe	1.42	1.34	1.25	1.16	1.05	0.93	0.81
PMB2H02.0090B.31	2	35	47	Qo	5.26	4.37	3.60	2.93	2.35	1.85	1.43
				Pe	1.73	1.64	1.54	1.43	1.30	1.17	1.03
		38	50	Qo	5.05	4.19	3.45	2.80	2.24	1.76	1.35
				Pe	1.81	1.71	1.60	1.48	1.35	1.20	1.05
		41	53	Qo	4.84	4.01	3.30	2.67	2.14	1.67	1.28
				Pe	1.90	1.79	1.66	1.53	1.39	1.23	1.07
PMB2H02.0126B.31T	2	35	44	Qo	5.48	4.56	3.76	3.06	2.46	1.95	1.51
				Pe	1.64	1.56	1.47	1.37	1.26	1.14	1.01
		38	47	Qo	5.26	4.37	3.60	2.93	2.35	1.85	1.43
				Pe	1.73	1.64	1.54	1.43	1.30	1.17	1.03
		41	50	Qo	5.05	4.19	3.45	2.80	2.24	1.76	1.35
				Pe	1.81	1.71	1.60	1.48	1.35	1.20	1.05
PMB2G02.0110B.31	2	35	47	Qo	6.14	5.13	4.24	3.47	2.81	2.23	1.74
				Pe	1.98	1.90	1.80	1.69	1.56	1.42	1.26
		38	50	Qo	5.91	4.92	4.07	3.32	2.68	2.12	1.65
				Pe	2.08	1.98	1.87	1.75	1.60	1.45	1.28
		41	53	Qo	5.67	4.73	3.90	3.18	2.56	2.02	1.56
				Pe	2.17	2.06	1.94	1.80	1.65	1.48	1.30
PMB2G02.0138B.41T	2	35	44	Qo	6.39	5.34	4.42	3.62	2.94	2.34	1.83
				Pe	1.88	1.82	1.73	1.63	1.52	1.39	1.24
		38	47	Qo	6.14	5.13	4.24	3.47	2.81	2.23	1.74
				Pe	1.98	1.90	1.80	1.69	1.56	1.42	1.26
		41	50	Qo	5.91	4.92	4.07	3.32	2.68	2.12	1.65
				Pe	2.08	1.98	1.87	1.75	1.60	1.45	1.28
PMB2F03.0126B.31	3	35	47	Qo	7.61	6.32	5.21	4.25	3.42	2.72	2.12
				Pe	2.46	2.33	2.20	2.05	1.89	1.72	1.54
		38	50	Qo	7.28	6.05	4.98	4.05	3.25	2.57	2.00
				Pe	2.58	2.44	2.29	2.13	1.95	1.76	1.57
		41	53	Qo	6.96	5.77	4.74	3.85	3.08	2.43	1.88
				Pe	2.70	2.55	2.38	2.20	2.01	1.80	1.59

Capacity based on 20°C Suction Temperature with no Sub-Cooling
 Eden cannot guarantee performance of the Condensing Units if non-standard fan motors are used

POLAPAK Medium Temperature Series

Performance Data

Capacity(kW)



Compressor Model	Nominal Power (HP)	Ambient Temperature (°C)	SCT (°C)	Refrigerating Capacity Qo(kW) Power Input Pe(kW)							
				Evaporating Temperature (°C)							
				5	0	-5	-10	-15	-20	-25	
PMB2F03.0187B.41T	3	35	44	Qo	7.93	6.80	5.44	4.45	3.59	2.86	2.24
				Pe	2.33	2.23	2.11	1.98	1.84	1.68	1.51
		38	47	Qo	7.61	6.32	5.21	4.25	3.42	2.72	2.12
				Pe	2.46	2.33	2.20	2.05	1.89	1.72	1.54
		41	50	Qo	7.28	6.05	4.98	4.05	3.25	2.57	2.00
				Pe	2.58	2.44	2.29	2.13	1.95	1.76	1.57
PMB2E03.0187B.41	3	35	47	Qo	9.58	7.95	6.53	5.30	4.24	3.32	2.54
				Pe	2.82	2.69	2.54	2.35	2.15	1.92	1.69
		38	50	Qo	9.20	7.63	6.27	5.08	4.05	3.17	2.41
				Pe	2.95	2.80	2.63	2.43	2.21	1.97	1.72
		41	53	Qo	8.84	7.32	6.00	4.86	3.87	3.02	2.29
				Pe	3.08	2.91	2.72	2.50	2.27	2.02	1.75
PMB2E03.0227S.51T	3	35	44	Qo	9.96	8.27	6.81	5.53	4.43	3.49	2.68
				Pe	2.69	2.58	2.44	2.28	2.09	1.88	1.65
		38	47	Qo	9.58	7.95	6.53	5.30	4.24	3.32	2.54
				Pe	2.82	2.69	2.54	2.35	2.15	1.92	1.69
		41	50	Qo	9.20	7.63	6.27	5.08	4.05	3.17	2.41
				Pe	2.95	2.80	2.63	2.43	2.21	1.97	1.72
PMB2D03.0227S.51	3	35	47	Qo	11.41	9.49	7.81	6.35	5.09	4.01	3.09
				Pe	3.39	3.24	3.05	2.83	2.58	2.31	2.03
		38	50	Qo	10.97	9.12	7.50	6.09	4.88	3.83	2.93
				Pe	3.55	3.38	3.17	2.92	2.66	2.37	2.07
		41	53	Qo	10.54	8.75	7.19	5.84	4.66	3.66	2.79
				Pe	3.72	3.52	3.28	3.02	2.74	2.43	2.12
PMB2D03.0280S.51T	3	35	44	Qo	11.86	9.87	8.13	6.62	5.32	4.20	3.24
				Pe	3.22	3.10	2.93	2.73	2.50	2.25	1.98
		38	47	Qo	11.41	9.49	7.81	6.35	5.09	4.01	3.09
				Pe	3.39	3.24	3.05	2.83	2.58	2.31	2.03
		41	50	Qo	10.97	9.12	7.50	6.09	4.88	3.83	2.93
				Pe	3.55	3.38	3.17	2.92	2.66	2.37	2.07
PMB2C04.0280S.51	4	35	47	Qo	13.99	11.66	9.62	7.86	6.33	5.01	3.88
				Pe	4.14	3.97	3.75	3.48	3.19	2.87	2.54
		38	50	Qo	13.47	11.22	9.25	7.54	6.07	4.79	3.71
				Pe	4.35	4.14	3.90	3.61	3.30	2.96	2.61
		41	53	Qo	12.95	10.78	8.89	7.24	5.82	4.59	3.54
				Pe	4.55	4.32	4.04	3.74	3.40	3.04	2.67
PMB2C04.0337S.51T	4	35	44	Qo	14.53	12.11	10.01	8.18	6.60	5.23	4.07
				Pe	3.94	3.79	3.60	3.36	3.09	2.79	2.48
		38	47	Qo	13.99	11.66	9.62	7.86	6.33	5.01	3.88
				Pe	4.14	3.97	3.75	3.48	3.19	2.87	2.54
		41	50	Qo	13.47	11.22	9.25	7.54	6.07	4.79	3.71
				Pe	4.35	4.14	3.90	3.61	3.30	2.96	2.61
PMB4F05.0280S.51	5	35	47	Qo	15.08	12.49	10.23	8.28	6.60	5.16	3.94
				Pe	4.38	4.18	3.93	3.63	3.30	2.95	2.57
		38	50	Qo	14.47	11.97	9.80	7.91	6.29	4.91	3.73
				Pe	4.57	4.34	4.06	3.74	3.39	3.01	2.62
		41	53	Qo	13.88	11.47	9.37	7.56	6.00	4.66	3.53
				Pe	4.76	4.50	4.19	3.85	3.47	3.08	2.66
PMB4F05.0376S.51T	5	35	44	Qo	15.71	13.02	10.68	8.66	6.92	5.43	4.16
				Pe	4.18	4.01	3.79	3.52	3.22	2.88	2.53
		38	47	Qo	15.08	12.49	10.23	8.28	6.60	5.16	3.94
				Pe	4.38	4.18	3.93	3.63	3.30	2.95	2.57
		41	50	Qo	14.47	11.97	9.80	7.91	6.29	4.91	3.73
				Pe	4.57	4.34	4.06	3.74	3.39	3.01	2.62

Capacity based on 20°C Suction Temperature with no Sub-Cooling
 Eden cannot guarantee performance of the Condensing Units if non-standard fan motors are used

POLAPAK Medium Temperature Series
Performance Data
Capacity(kW)



Compressor Model	Nominal Power (HP)	Ambient Temperature (°C)	SCT (°C)	Refrigerating Capacity Qo(kW) Power Input Pe(kW)							
				Evaporating Temperature (°C)							
				5	0	-5	-10	-15	-20	-25	
PMB4E06.0337S.51	6	35	47	Qo	19.14	15.87	13.02	10.56	8.44	6.62	5.08
				Pe	5.61	5.35	5.02	4.65	4.22	3.77	3.29
		38	50	Qo	18.37	15.22	12.48	10.11	8.06	6.31	4.81
				Pe	5.87	5.57	5.21	4.80	4.34	3.86	3.36
		41	53	Qo	17.83	14.59	11.95	9.66	7.69	6.00	4.57
				Pe	6.13	5.79	5.29	4.95	4.46	3.95	3.42
PMB4E06.0466S.61T	6	35	44	Qo	19.92	16.53	13.59	11.04	8.84	6.96	5.35
				Pe	5.34	5.12	4.84	4.49	4.10	3.68	3.23
		38	47	Qo	19.14	15.87	13.02	10.56	8.44	6.62	5.08
				Pe	5.61	5.35	5.02	4.65	4.22	3.77	3.29
		41	50	Qo	18.37	15.22	12.48	10.11	8.06	6.31	4.81
				Pe	5.87	5.57	5.21	4.80	4.34	3.86	3.36
PMB4D07.0412S.61	7	35	47	Qo	22.80	18.94	15.58	12.66	10.15	7.99	6.16
				Pe	6.61	6.32	5.95	5.52	5.04	4.52	3.97
		38	50	Qo	21.90	18.18	14.94	12.13	9.70	7.62	5.85
				Pe	6.92	6.58	6.17	5.70	5.19	4.64	4.06
		41	53	Qo	21.00	17.44	14.32	11.61	9.27	7.27	5.56
				Pe	7.23	6.84	6.39	5.89	5.34	4.75	4.15
PMB4D07.0564S.61T	7	35	44	Qo	23.70	19.71	16.23	13.21	10.61	8.38	6.48
				Pe	6.29	6.05	5.73	5.34	4.89	4.41	3.89
		38	47	Qo	22.80	18.94	15.58	12.66	10.15	7.99	6.16
				Pe	6.61	6.32	5.95	5.52	5.04	4.52	3.97
		41	50	Qo	21.90	18.18	14.94	12.13	9.70	7.62	5.85
				Pe	6.92	6.58	6.17	5.70	5.19	4.64	4.06
PMB4C09.0524S.61	9	35	47	Qo	28.00	23.30	19.20	15.67	12.61	9.99	7.75
				Pe	8.23	7.87	7.42	6.89	6.29	5.66	4.99
		38	50	Qo	26.90	22.40	18.44	15.03	12.08	9.55	7.39
				Pe	8.65	8.23	7.72	7.14	6.50	5.82	5.12
		41	53	Qo	25.90	21.50	17.70	14.41	11.57	9.13	7.05
				Pe	9.06	8.58	8.02	7.39	6.71	5.99	5.25
PMB4C09.0760R.52T	9	35	44	Qo	29.10	24.20	19.99	16.32	13.16	10.45	8.13
				Pe	7.81	7.51	7.11	6.63	6.09	5.49	4.87
		38	47	Qo	28.00	23.30	19.20	15.67	12.61	9.99	7.75
				Pe	8.23	7.87	7.42	6.89	6.29	5.66	4.99
		41	50	Qo	26.90	22.40	18.44	15.03	12.08	9.55	7.39
				Pe	8.65	8.23	7.72	7.14	6.50	5.82	5.12
PMB4V10.0524S.61	10	35	47	Qo	30.70	25.40	20.70	16.68	13.19	10.20	7.65
				Pe	8.33	7.90	7.37	6.77	6.10	5.40	4.67
		38	50	Qo	29.60	24.40	19.86	15.94	12.55	9.66	7.19
				Pe	8.67	8.17	7.59	6.94	6.23	5.48	4.71
		41	53	Qo	28.40	23.40	18.99	15.19	11.92	9.12	-
				Pe	8.99	8.44	7.80	7.10	6.34	5.55	-
PMB4V10.0760R.52T	10	35	44	Qo	31.90	26.40	21.60	17.43	13.83	10.75	8.11
				Pe	7.97	7.60	7.13	6.59	5.97	5.31	4.62
		38	47	Qo	30.70	25.40	20.70	16.68	13.19	10.20	7.65
				Pe	8.33	7.90	7.37	6.77	6.10	5.40	4.67
		41	50	Qo	29.60	24.40	19.86	15.94	12.55	9.66	7.19
				Pe	8.67	8.17	7.59	6.94	6.23	5.48	4.71
PMB4T12.0653R.52	12	35	47	Qo	37.00	30.60	25.10	20.20	16.08	12.50	9.45
				Pe	10.19	9.67	9.04	8.31	7.51	6.67	5.79
		38	50	Qo	35.60	29.40	24.10	19.37	15.33	11.86	8.91
				Pe	10.62	10.03	9.33	8.54	7.68	6.78	5.86
		41	53	Qo	34.30	28.30	23.00	18.50	14.59	11.24	-
				Pe	11.04	10.38	9.61	8.76	7.84	6.89	-

Capacity based on 20°C Suction Temperature with no Sub-Cooling
 Eden cannot guarantee performance of the Condensing Units if non-standard fan motors are used

POLPAK Medium Temperature Series

Performance Data

Capacity(kW)



Compressor Model	Nominal Power (HP)	Ambient Temperature (°C)	SCT (°C)	Refrigerating Capacity Qo(kW) Power Input Pe(kW)							
				Evaporating Temperature (°C)							
				5	0	-5	-10	-15	-20	-25	
PMB4T12.0881R.52T	12	35	44	Qo	38.40	31.80	26.10	21.10	16.83	13.14	9.99
				Pe	9.74	9.29	8.73	8.07	7.33	6.54	5.71
		38	47	Qo	37.00	30.60	25.10	20.20	16.08	12.50	9.45
				Pe	10.19	9.67	9.04	8.31	7.51	6.67	5.79
		41	50	Qo	35.60	29.40	24.10	19.37	15.33	11.86	8.91
				Pe	10.62	10.03	9.33	8.54	7.68	6.78	5.86
PMB4P15.0760R.52	15	35	47	Qo	42.60	35.10	28.60	23.00	18.13	13.97	10.42
				Pe	11.65	11.03	10.26	9.39	8.44	7.42	6.37
		38	50	Qo	41.00	33.70	27.40	21.90	17.23	13.20	9.77
				Pe	12.13	11.41	10.57	9.62	8.60	7.51	6.40
		41	53	Qo	39.30	32.30	26.20	20.90	16.34	12.44	-
				Pe	12.58	11.78	10.86	9.83	8.74	7.59	-
PMB4P15.1038R.53T	15	35	44	Qo	44.20	36.50	29.80	24.00	19.04	14.74	11.08
				Pe	11.16	10.62	9.94	9.15	8.26	7.31	6.31
		38	47	Qo	42.60	35.10	28.60	23.00	18.13	13.97	10.42
				Pe	11.65	11.03	10.26	9.39	8.44	7.42	6.37
		41	50	Qo	41.00	33.70	27.40	21.90	17.23	13.20	9.77
				Pe	12.13	11.41	10.57	9.62	8.60	7.51	6.40
PMB4N20.0881R.52	20	35	47	Qo	50.10	41.40	33.80	27.30	21.60	16.75	12.61
				Pe	13.63	12.93	12.07	11.09	10.01	8.86	7.68
		38	50	Qo	48.20	39.80	32.40	26.10	20.60	15.88	11.87
				Pe	14.20	13.40	12.45	11.38	10.22	9.00	7.76
		41	53	Qo	46.30	38.10	31.00	24.90	19.57	15.02	-
				Pe	14.76	13.86	12.81	11.66	10.42	9.13	-
PMB4N20.1158R.53T	20	35	44	Qo	51.90	43.00	35.20	28.50	22.60	17.63	13.36
				Pe	13.04	12.44	11.67	10.78	9.78	8.70	7.59
		38	47	Qo	50.10	41.40	33.80	27.30	21.60	16.75	12.61
				Pe	13.63	12.93	12.07	11.09	10.01	8.86	7.68
		41	50	Qo	48.20	39.80	32.40	26.10	20.60	15.88	11.87
				Pe	14.20	13.40	12.45	11.38	10.22	9.00	7.76
PMB4J22.1038R.53	22	35	47	Qo	56.50	46.70	38.20	30.80	24.40	18.88	14.20
				Pe	15.51	14.69	13.69	12.55	11.31	9.99	8.64
		38	50	Qo	54.40	44.90	36.60	29.40	23.20	17.89	13.36
				Pe	16.17	15.24	14.13	12.89	11.55	10.15	8.72
		41	53	Qo	52.20	43.00	35.00	28.10	22.10	16.91	-
				Pe	16.82	15.76	14.55	13.21	11.77	10.29	-
PMB4J22.1268R.54T	22	35	44	Qo	58.60	48.50	39.70	32.10	25.50	19.87	15.04
				Pe	14.82	14.12	13.23	12.20	11.04	9.81	8.53
		38	47	Qo	56.50	46.70	38.20	30.80	24.40	18.88	14.20
				Pe	15.51	14.69	13.69	12.55	11.31	9.99	8.64
		41	50	Qo	54.40	44.90	36.60	29.40	23.20	17.89	13.36
				Pe	16.17	15.24	14.13	12.89	11.55	10.15	8.72
PMB4H25.1088R.53	25	35	47	Qo	66.50	55.10	45.20	36.80	29.10	22.70	17.25
				Pe	18.25	17.34	16.23	14.96	13.56	12.08	10.55
		38	50	Qo	64.10	53.00	43.40	35.00	27.80	21.60	16.30
				Pe	19.05	18.01	16.78	15.39	13.89	12.31	10.71
		41	53	Qo	61.60	50.90	41.60	33.50	26.50	20.50	-
				Pe	19.82	18.66	17.30	15.80	14.20	12.53	-
PMB4H25.1540R.54T	25	35	44	Qo	68.90	57.20	47.00	38.10	30.40	23.80	18.21
				Pe	17.43	16.66	15.67	14.51	13.21	11.82	10.38
		38	47	Qo	66.50	55.10	45.20	36.80	29.10	22.70	17.25
				Pe	18.25	17.34	16.23	14.96	13.56	12.08	10.55
		41	50	Qo	64.10	53.00	43.40	35.00	27.80	21.60	16.30
				Pe	19.05	18.01	16.78	15.39	13.89	12.31	10.71

Capacity based on 20°C Suction Temperature with no Sub-Cooling
 Eden cannot guarantee performance of the Condensing Units if non-standard fan motors are used

POLAPAK Medium Temperature Series

Performance Data

Capacity(kW)



Compressor Model	Nominal Power (HP)	Ambient Temperature (°C)	SCT (°C)	Refrigerating Capacity Qo(kW) Power Input Pe(kW)							
				Evaporating Temperature (°C)							
				5	0	-5	-10	-15	-20	-25	
PMB4G30.1260R.53	30	35	47	Qo	77.00	63.90	52.50	42.60	34.00	26.60	20.30
				Pe	21.00	19.97	18.73	17.29	15.72	14.05	12.33
		38	50	Qo	74.20	61.50	50.40	40.80	32.50	25.30	19.24
				Pe	21.90	20.80	19.37	17.81	16.12	14.35	12.54
		41	53	Qo	71.50	59.10	48.40	39.10	31.00	24.10	-
				Pe	22.80	21.50	20.00	18.31	16.51	14.64	-
PMB4G30.1707R.53T	30	35	44	Qo	79.70	66.20	54.50	44.30	35.50	27.90	21.40
				Pe	20.00	19.17	18.06	16.75	15.30	13.73	12.11
		38	47	Qo	77.00	63.90	52.50	42.60	34.00	26.60	20.30
				Pe	21.00	19.97	18.73	17.29	15.72	14.05	12.33
		41	50	Qo	74.20	61.50	50.40	40.80	32.50	25.30	19.24
				Pe	21.90	20.80	19.37	17.81	16.12	14.35	12.54
PMB4F35.1540R.54	35	35	47	Qo	91.80	76.20	62.50	50.70	40.40	31.60	24.10
				Pe	25.40	24.10	22.60	20.80	18.83	16.77	14.66
		38	50	Qo	88.50	73.30	60.10	48.60	38.70	30.10	22.80
				Pe	26.60	25.10	23.40	21.40	19.32	17.13	14.91
		41	53	Qo	85.20	70.50	57.60	46.50	36.90	28.60	-
				Pe	27.70	26.10	24.10	22.00	19.78	17.46	-
PMB4F35.2030R.63T	35	35	44	Qo	95.10	79.00	65.00	52.80	42.20	33.20	25.40
				Pe	24.20	23.10	21.80	20.10	18.32	16.39	14.40
		38	47	Qo	91.80	76.20	62.50	50.70	40.40	31.60	24.10
				Pe	25.40	24.10	22.60	20.80	18.83	16.77	14.66
		41	50	Qo	88.50	73.30	60.10	48.60	38.70	30.10	22.80
				Pe	26.60	25.10	23.40	21.40	19.32	17.13	14.91
PMB6J33.1385R.54	33	35	47	Qo	84.70	70.00	57.20	46.10	36.60	28.30	21.30
				Pe	23.20	22.00	20.50	18.81	16.97	15.02	13.02
		38	50	Qo	81.60	67.30	54.90	44.10	34.80	26.80	20.00
				Pe	24.10	22.80	21.10	19.30	17.33	15.26	13.15
		41	53	Qo	78.40	64.50	52.50	42.10	33.10	25.40	-
				Pe	25.10	23.50	21.70	19.77	17.66	15.47	-
PMB6J33.1890R.63T	33	35	44	Qo	87.90	72.80	59.60	48.20	38.30	29.80	22.60
				Pe	22.20	21.10	19.81	18.28	16.58	14.76	12.87
		38	47	Qo	84.70	70.00	57.20	46.10	36.60	28.30	21.30
				Pe	23.20	22.00	20.50	18.81	16.97	15.02	13.02
		41	50	Qo	81.60	67.30	54.90	44.10	34.80	26.80	20.00
				Pe	24.10	22.80	21.10	19.30	17.33	15.26	13.15
PMB6H35.1625R.54	35	35	47	Qo	99.70	82.70	67.80	54.80	43.70	34.10	25.90
				Pe	27.60	26.20	24.50	22.50	20.40	18.13	15.82
		38	50	Qo	96.10	79.50	65.10	52.50	41.70	32.40	24.40
				Pe	28.90	27.30	25.40	23.20	20.90	18.48	16.05
		41	53	Qo	92.50	76.40	62.40	50.20	39.70	30.70	-
				Pe	30.10	28.30	26.20	23.80	21.40	18.82	-
PMB6H35.2254R.64T	35	35	44	Qo	103.40	85.80	70.50	57.20	45.70	35.80	27.30
				Pe	26.40	25.20	23.60	21.80	19.86	17.75	15.56
		38	47	Qo	99.70	82.70	67.80	54.80	43.70	34.10	25.90
				Pe	27.60	26.20	24.50	22.50	20.40	18.13	15.82
		41	50	Qo	96.10	79.50	65.10	52.50	41.70	32.40	24.40
				Pe	28.90	27.30	25.40	23.20	20.90	18.48	16.05
PMB6G40.1890R.63	40	35	47	Qo	114.50	94.90	77.80	63.00	50.10	39.10	29.70
				Pe	31.50	30.00	28.00	25.90	23.50	20.90	18.03
		38	50	Qo	110.30	91.30	74.70	60.30	47.90	37.20	28.10
				Pe	32.90	31.10	29.00	26.60	24.00	21.30	18.56
		41	53	Qo	106.20	87.70	71.60	57.70	45.60	35.30	-
				Pe	34.20	32.20	29.90	27.30	24.50	21.70	-

Capacity based on 20°C Suction Temperature with no Sub-Cooling
 Eden cannot guarantee performance of the Condensing Units if non-standard fan motors are used

POLPAK Medium Temperature Series

Performance Data

Capacity(kW)



Compressor Model	Nominal Power (HP)	Ambient Temperature (°C)	SCT (°C)	Refrigerating Capacity Qo(kW) Power Input Pe(kW)							
				Evaporating Temperature (°C)							
				5	0	-5	-10	-15	-20	-25	
PMB6G40.2500R.64T	40	35	44	Qo	118.70	98.50	80.90	65.60	52.40	41.10	31.40
				Pe	30.10	28.80	27.10	25.10	22.90	20.50	18.01
		38	47	Qo	114.50	94.90	77.80	63.00	50.10	39.10	29.70
				Pe	31.50	30.00	28.00	25.90	23.50	20.90	18.03
		41	50	Qo	110.30	91.30	74.70	60.30	47.90	37.20	28.10
				Pe	32.90	31.10	29.00	26.80	24.00	21.30	18.56
PMB6F50.2254R.64	50	35	47	Qo	137.70	114.20	93.80	76.00	60.70	47.50	36.20
				Pe	38.20	36.30	34.10	31.50	28.70	25.60	22.60
		38	50	Qo	132.80	110.00	90.10	72.90	58.00	45.20	34.20
				Pe	39.90	37.80	35.20	32.40	29.40	26.20	22.90
		41	53	Qo	127.80	105.70	86.50	69.70	55.30	42.90	-
				Pe	41.50	39.10	36.40	33.30	30.00	26.70	-
PMB6G60.2650R.64	60	35	47	Qo	160.10	134.00	110.70	89.80	70.80	-	-
				Pe	46.90	44.60	42.00	39.20	36.50	-	-
		38	50	Qo	154.30	129.00	106.30	85.60	66.70	-	-
				Pe	48.80	46.20	43.40	40.60	38.10	-	-
		41	53	Qo	148.60	124.00	101.70	81.30	-	-	-
				Pe	50.70	47.90	44.90	42.10	-	-	-

Capacity based on 20°C Suction Temperature with no Sub-Cooling
Eden cannot guarantee performance of the Condensing Units if non-standard fan motors are used

POLAPAK Low Temperature Series
Performance Data
Capacity(kW)

R404A/R507A 
50Hz

Compressor Model	Nominal Power (HP)	Ambient Temperature (°C)	SCT (°C)	Refrigerating Capacity Qo(kW) Power Input Pe(kW)					
				Evaporating Temperature (°C)				Qo	Pe
				-25	-30	-35	-40		
PLB2KA5.0054B.21	0.5	35	44	Qo	0.81	0.57	0.37	0.20	
				Pe	0.65	0.56	0.46	0.34	
		38	47	Qo	0.73	0.51	0.33	0.17	
				Pe	0.66	0.56	0.44	0.32	
		41	50	Qo	0.67	0.46	0.29	0.14	
				Pe	0.66	0.55	0.43	0.30	
PLB2KA5.0064B.21T	0.5	35	41	Qo	0.88	0.63	0.42	0.24	
				Pe	0.65	0.57	0.47	0.36	
		38	44	Qo	0.81	0.57	0.37	0.20	
				Pe	0.65	0.56	0.46	0.34	
		41	47	Qo	0.73	0.51	0.33	0.17	
				Pe	0.66	0.56	0.44	0.32	
PLB2JA7.0054B.21	0.7	35	44	Qo	1.16	0.85	0.59	0.37	
				Pe	0.88	0.76	0.63	0.48	
		38	47	Qo	1.07	0.77	0.52	0.31	
				Pe	0.89	0.76	0.61	0.46	
		41	50	Qo	0.98	0.70	0.46	0.26	
				Pe	0.89	0.75	0.60	0.44	
PLB2JA7.0064B.21T	0.7	35	41	Qo	1.26	0.93	0.65	0.42	
				Pe	0.88	0.76	0.64	0.50	
		38	44	Qo	1.16	0.85	0.59	0.37	
				Pe	0.88	0.76	0.63	0.48	
		41	47	Qo	1.07	0.77	0.52	0.31	
				Pe	0.89	0.76	0.61	0.46	
PLB2H01.0054B.21	1	35	44	Qo	1.49	1.10	0.78	0.50	
				Pe	1.09	0.93	0.77	0.60	
		38	47	Qo	1.37	1.00	0.69	0.43	
				Pe	1.09	0.92	0.75	0.58	
		41	50	Qo	1.25	0.91	0.61	0.37	
				Pe	1.09	0.91	0.73	0.55	
PLB2H01.0090B.31T	1	35	41	Qo	1.61	1.21	0.86	0.57	
				Pe	1.08	0.94	0.78	0.63	
		38	44	Qo	1.49	1.10	0.78	0.50	
				Pe	1.09	0.93	0.77	0.60	
		41	47	Qo	1.37	1.00	0.69	0.43	
				Pe	1.09	0.92	0.75	0.58	
PLB2G02.0064B.21	2	35	44	Qo	1.81	1.37	0.99	0.68	
				Pe	1.32	1.14	0.96	0.78	
		38	47	Qo	1.68	1.26	0.91	0.61	
				Pe	1.34	1.15	0.96	0.77	
		41	50	Qo	1.56	1.16	0.82	0.54	
				Pe	1.35	1.16	0.96	0.76	
PLB2G02.0110B.31T	2	35	41	Qo	1.95	1.48	1.08	0.75	
				Pe	1.30	1.14	0.96	0.79	
		38	44	Qo	1.81	1.37	0.99	0.68	
				Pe	1.32	1.14	0.96	0.78	
		41	47	Qo	1.68	1.26	0.91	0.61	
				Pe	1.34	1.15	0.96	0.77	
PLB2F02.0090B.31	2	35	44	Qo	2.23	1.68	1.21	0.81	
				Pe	1.63	1.41	1.19	0.97	
		38	47	Qo	2.06	1.55	1.10	0.73	
				Pe	1.66	1.43	1.19	0.97	
		41	50	Qo	1.91	1.42	1.00	0.65	
				Pe	1.68	1.44	1.20	0.97	

Capacity based on 20°C Suction Temperature with no Sub-Cooling
 Head Fan is required
 Eden cannot guarantee performance of the Condensing Units if non-standard fan motors are used.

POLAPAK Low Temperature Series
Performance Data
Capacity(kW)

R404A/R507A 
50Hz

Compressor Model	Nominal Power (HP)	Ambient Temperature (°C)	SCT (°C)	Refrigerating Capacity Qo(kW) Power Input Pe(kW)				
				Evaporating Temperature (°C)				
				-25	-30	-35	-40	
PLB2F02.0128B.31T	2	35	41	Qo	2.40	1.81	1.32	0.90
				Pe	1.61	1.40	1.18	0.97
		38	44	Qo	2.23	1.68	1.21	0.81
				Pe	1.63	1.41	1.19	0.97
		41	47	Qo	2.06	1.55	1.10	0.73
				Pe	1.66	1.43	1.19	0.97
PLB2E02.0110B.31	2	35	44	Qo	2.89	2.18	1.58	1.07
				Pe	1.79	1.53	1.27	1.01
		38	47	Qo	2.67	2.00	1.43	0.95
				Pe	1.80	1.52	1.25	0.99
		41	50	Qo	2.45	1.82	1.28	0.83
				Pe	1.80	1.51	1.23	0.95
PLB2E02.0138B.41T	2	35	41	Qo	3.11	2.36	1.72	1.18
				Pe	1.77	1.53	1.28	1.04
		38	44	Qo	2.89	2.18	1.58	1.07
				Pe	1.79	1.53	1.27	1.01
		41	47	Qo	2.67	2.00	1.43	0.95
				Pe	1.80	1.52	1.25	0.99
PLB2D02.0128B.31	2	35	44	Qo	3.51	2.67	1.95	1.34
				Pe	2.20	1.89	1.58	1.28
		38	47	Qo	3.25	2.46	1.78	1.20
				Pe	2.22	1.89	1.57	1.25
		41	50	Qo	2.99	2.24	1.60	1.07
				Pe	2.23	1.88	1.55	1.22
PLB2D02.0187B.41T	2	35	41	Qo	3.76	2.88	2.12	1.48
				Pe	2.18	1.88	1.59	1.30
		38	44	Qo	3.51	2.67	1.95	1.34
				Pe	2.20	1.89	1.58	1.28
		41	47	Qo	3.25	2.46	1.78	1.20
				Pe	2.22	1.89	1.57	1.25
PLB2C03.0138B.41	3	35	44	Qo	4.43	3.40	2.52	1.78
				Pe	2.75	2.39	2.03	1.68
		38	47	Qo	4.12	3.15	2.32	1.62
				Pe	2.79	2.40	2.02	1.66
		41	50	Qo	3.81	2.89	2.11	1.45
				Pe	2.81	2.41	2.01	1.64
PLB2C03.0227S.51T	3	35	41	Qo	4.73	3.65	2.73	1.94
				Pe	2.71	2.37	2.02	1.68
		38	44	Qo	4.43	3.40	2.52	1.78
				Pe	2.75	2.39	2.03	1.68
		41	47	Qo	4.12	3.15	2.32	1.62
				Pe	2.79	2.40	2.02	1.66
PLB4F03.0138B.41	3	35	44	Qo	4.74	3.67	2.78	2.04
				Pe	3.04	2.65	2.26	1.88
		38	47	Qo	4.44	3.42	2.58	1.89
				Pe	3.08	2.67	2.26	1.87
		41	50	Qo	4.12	3.17	2.38	1.73
				Pe	3.11	2.68	2.26	1.85
PLB4F03.0280S.51T	3	35	41	Qo	5.04	3.91	2.97	2.20
				Pe	2.99	2.62	2.25	1.89
		38	44	Qo	4.74	3.67	2.78	2.04
				Pe	3.04	2.65	2.26	1.88
		41	47	Qo	4.44	3.42	2.58	1.89
				Pe	3.08	2.67	2.26	1.87

Capacity based on 20°C Suction Temperature with no Sub-Cooling
 Head Fan is required
 Eden cannot guarantee performance of the Condensing Units if non-standard fan motors are used.

POLAPAK Low Temperature Series
Performance Data
Capacity(kW)

R404A/R507A 
50Hz

Compressor Model	Nominal Power (HP)	Ambient Temperature (°C)	SCT (°C)	Refrigerating Capacity Qo(kW) Power Input Pe(kW)				
				Evaporating Temperature (°C)				
				-25	-30	-35	-40	
PLB4E04.0227S.51	4	35	44	Qo	6.02	4.65	3.50	2.57
				Pe	3.82	3.31	2.79	2.30
		38	47	Qo	5.63	4.33	3.26	2.37
				Pe	3.88	3.33	2.80	2.29
		41	50	Qo	5.24	4.02	3.01	2.17
				Pe	3.92	3.35	2.80	2.27
PLB4E04.0337S.51T	4	35	41	Qo	6.40	4.95	3.75	2.76
				Pe	3.76	3.27	2.78	2.31
		38	44	Qo	6.02	4.65	3.50	2.57
				Pe	3.82	3.31	2.79	2.30
		41	47	Qo	5.63	4.33	3.26	2.37
				Pe	3.88	3.33	2.80	2.29
PLB4D05.0227S.51	5	35	44	Qo	7.18	5.54	4.18	3.07
				Pe	4.53	3.92	3.33	2.76
		38	47	Qo	6.72	5.17	3.89	2.83
				Pe	4.59	3.96	3.34	2.76
		41	50	Qo	6.26	4.80	3.60	2.60
				Pe	4.65	3.99	3.35	2.74
PLB4D05.0378S.51T	5	35	41	Qo	7.64	5.91	4.48	3.30
				Pe	4.45	3.88	3.31	2.76
		38	44	Qo	7.18	5.54	4.18	3.07
				Pe	4.53	3.92	3.33	2.76
		41	47	Qo	6.72	5.17	3.89	2.83
				Pe	4.59	3.96	3.34	2.76
PLB4C06.0280S.51	6	35	44	Qo	8.57	6.58	4.92	3.56
				Pe	5.33	4.60	3.88	3.20
		38	47	Qo	8.02	6.13	4.57	3.28
				Pe	5.41	4.64	3.89	3.19
		41	50	Qo	7.48	5.69	4.22	3.01
				Pe	5.47	4.67	3.90	3.17
PLB4C06.0412S.61T	6	35	41	Qo	9.13	7.03	5.28	3.84
				Pe	5.25	4.55	3.87	3.21
		38	44	Qo	8.57	6.58	4.92	3.56
				Pe	5.33	4.60	3.88	3.20
		41	47	Qo	8.02	6.13	4.57	3.28
				Pe	5.41	4.64	3.89	3.19
PLB4V07.0337S.51	7	35	44	Qo	8.45	6.31	4.54	3.10
				Pe	5.06	4.25	3.48	2.76
		38	47	Qo	7.83	5.81	4.14	2.78
				Pe	5.12	4.27	3.47	2.73
		41	50	Qo	7.22	5.32	3.75	2.48
				Pe	5.17	4.29	3.46	2.69
PLB4V07.0412S.61T	7	35	41	Qo	9.07	6.82	4.95	3.42
				Pe	4.99	4.22	3.48	2.79
		38	44	Qo	8.45	6.31	4.54	3.10
				Pe	5.06	4.25	3.48	2.76
		41	47	Qo	7.83	5.81	4.14	2.78
				Pe	5.12	4.27	3.47	2.73
PLB4T09.0337S.51	9	35	44	Qo	10.52	7.96	5.84	4.11
				Pe	6.32	5.37	4.46	3.61
		38	47	Qo	9.79	7.37	5.37	3.74
				Pe	6.40	5.41	4.46	3.59
		41	50	Qo	9.06	6.79	4.90	3.38
				Pe	6.48	5.44	4.47	3.57

Capacity based on 20°C Suction Temperature with no Sub-Cooling
 Head Fan is required
 Eden cannot guarantee performance of the Condensing Units if non-standard fan motors are used.

POLAPAK Low Temperature Series
Performance Data
Capacity(kW)

R404A/R507A  +5°C
 -25°C
 -40°C
50Hz

Compressor Model	Nominal Power (HP)	Ambient Temperature (°C)	SCT (°C)	Refrigerating Capacity Qo(kW) Power Input Pe(kW)					
				Evaporating Temperature (°C)				Qo	Pe
				-25	-30	-35	-40		
PLB4T09.0524S.61T	9	35	41	Qo	11.26	8.56	6.32	4.49	
				Pe	6.23	5.32	4.44	3.63	
		38	44	Qo	10.52	7.96	5.84	4.11	
				Pe	6.32	5.37	4.46	3.61	
		41	47	Qo	9.79	7.37	5.37	3.74	
				Pe	6.40	5.41	4.46	3.59	
PLB4P12.0376S.51	12	35	44	Qo	11.61	8.64	6.20	4.21	
				Pe	6.87	5.75	4.67	3.65	
		38	47	Qo	10.73	7.93	5.63	3.76	
				Pe	6.89	5.72	4.59	3.55	
		41	50	Qo	9.86	7.22	5.07	3.32	
				Pe	6.89	5.67	4.50	3.42	
PLB4P12.0564S.61T	12	35	41	Qo	12.50	9.37	6.78	4.68	
				Pe	6.83	5.76	4.72	3.74	
		38	44	Qo	11.61	8.64	6.20	4.21	
				Pe	6.87	5.75	4.67	3.65	
		41	47	Qo	10.73	7.93	5.63	3.76	
				Pe	6.89	5.72	4.59	3.55	
PLB4N14.0412S.61	14	35	44	Qo	14.29	10.80	7.92	5.57	
				Pe	8.56	7.24	5.97	4.76	
		38	47	Qo	13.26	9.97	7.25	5.04	
				Pe	8.60	7.22	5.89	4.64	
		41	50	Qo	12.24	9.14	6.58	4.51	
				Pe	8.61	7.17	5.79	4.49	
PLB4N14.0653R.52T	14	35	41	Qo	15.31	11.63	8.59	6.11	
				Pe	8.49	7.24	6.02	4.85	
		38	44	Qo	14.29	10.80	7.92	5.57	
				Pe	8.56	7.24	5.97	4.76	
		41	47	Qo	13.26	9.97	7.25	5.04	
				Pe	8.60	7.22	5.89	4.64	
PLB4J15.0524S.61	15	35	44	Qo	17.08	13.05	9.66	6.83	
				Pe	10.00	8.63	7.28	5.99	
		38	47	Qo	15.95	12.12	8.90	6.22	
				Pe	10.10	8.66	7.25	5.91	
		41	50	Qo	14.81	11.20	8.16	5.64	
				Pe	10.18	8.67	7.21	5.82	
PLB4J15.0861R.52T	15	35	41	Qo	18.22	13.99	10.42	7.44	
				Pe	9.88	8.58	7.29	6.04	
		38	44	Qo	17.08	13.05	9.66	6.83	
				Pe	10.00	8.63	7.28	5.99	
		41	47	Qo	15.95	12.12	8.90	6.22	
				Pe	10.10	8.66	7.25	5.91	
PLB4H18.0653R.52	18	35	44	Qo	20.30	15.67	11.76	8.49	
				Pe	11.95	10.33	8.75	7.25	
		38	47	Qo	19.02	14.62	10.91	7.82	
				Pe	12.10	10.40	8.76	7.20	
		41	50	Qo	17.72	13.57	10.07	7.16	
				Pe	12.22	10.44	8.74	7.14	
PLB4H18.0905R.53T	18	35	41	Qo	21.60	16.73	12.61	9.16	
				Pe	11.78	10.24	8.72	7.27	
		38	44	Qo	20.30	15.67	11.76	8.49	
				Pe	11.95	10.33	8.75	7.25	
		41	47	Qo	19.02	14.62	10.91	7.82	
				Pe	12.10	10.40	8.76	7.20	

Capacity based on 20°C Suction Temperature with no Sub-Cooling
 Head Fan is required
 Eden cannot guarantee performance of the Condensing Units if non-standard fan motors are used.

POLAPAK Low Temperature Series
Performance Data
Capacity(kW)

R404A/R507A 
50Hz

Compressor Model	Nominal Power (HP)	Ambient Temperature (°C)	SCT (°C)	Refrigerating Capacity Qo(kW) Power Input Pe(kW)					
				Evaporating Temperature (°C)				Qo	Pe
				-25	-30	-35	-40		
PLB4G23.0760R.52	23	35	44	Qo	23.90	18.64	14.18	10.45	
				Pe	14.20	12.29	10.44	8.70	
		38	47	Qo	22.50	17.46	13.24	9.73	
				Pe	14.40	12.41	10.49	8.70	
		41	50	Qo	21.00	16.29	12.32	9.01	
				Pe	14.58	12.50	10.53	8.68	
PLB4G23.1088R.53T	23	35	41	Qo	25.40	19.81	15.11	11.18	
				Pe	13.96	12.14	10.37	8.69	
		38	44	Qo	23.90	18.64	14.18	10.45	
				Pe	14.20	12.29	10.44	8.70	
		41	47	Qo	22.50	17.46	13.24	9.73	
				Pe	14.40	12.41	10.49	8.70	
PLB4F28.0861R.52	28	35	44	Qo	28.60	22.30	16.93	12.36	
				Pe	17.06	14.74	12.46	10.25	
		38	47	Qo	26.90	20.90	15.78	11.41	
				Pe	17.27	14.85	12.46	10.16	
		41	50	Qo	25.20	19.49	14.61	10.44	
				Pe	17.45	14.91	12.42	10.04	
PLB4F28.1288R.54T	28	35	41	Qo	30.30	23.70	18.08	13.31	
				Pe	16.80	14.60	12.42	10.30	
		38	44	Qo	28.60	22.30	16.93	12.36	
				Pe	17.06	14.74	12.46	10.25	
		41	47	Qo	26.90	20.90	15.78	11.41	
				Pe	17.27	14.85	12.46	10.16	
PLB6J25.0760R.52	25	35	44	Qo	25.40	19.48	14.46	10.30	
				Pe	14.78	12.68	10.60	8.58	
		38	47	Qo	23.80	18.11	13.35	9.41	
				Pe	14.94	12.73	10.56	8.46	
		41	50	Qo	22.10	16.75	12.26	8.54	
				Pe	15.06	12.75	10.48	8.31	
PLB6J25.1088R.53T	25	35	41	Qo	27.10	20.90	15.59	11.20	
				Pe	14.59	12.60	10.61	8.67	
		38	44	Qo	25.40	19.48	14.46	10.30	
				Pe	14.78	12.68	10.60	8.58	
		41	47	Qo	23.80	18.11	13.35	9.41	
				Pe	14.94	12.73	10.56	8.46	
PLB6H28.0861R.52	28	35	44	Qo	29.90	23.10	17.33	12.52	
				Pe	17.61	15.16	12.75	10.43	
		38	47	Qo	28.00	21.50	16.06	11.50	
				Pe	17.83	15.26	12.74	10.32	
		41	50	Qo	26.10	19.97	14.80	10.49	
				Pe	18.01	15.32	12.69	10.18	
PLB6H28.1432R.54T	28	35	41	Qo	31.80	24.60	18.60	13.54	
				Pe	17.35	15.03	12.72	10.50	
		38	44	Qo	29.90	23.10	17.33	12.52	
				Pe	17.61	15.16	12.75	10.43	
		41	47	Qo	28.00	21.50	16.06	11.50	
				Pe	17.83	15.26	12.74	10.32	
PLB6G34.1088R.53	34	35	44	Qo	36.10	28.30	21.70	16.19	
				Pe	21.60	18.86	16.15	13.55	
		38	47	Qo	34.00	26.60	20.30	15.07	
				Pe	22.00	19.12	16.27	13.57	
		41	50	Qo	31.80	24.80	18.92	13.93	
				Pe	22.40	19.33	16.35	13.54	

Capacity based on 20°C Suction Temperature with no Sub-Cooling
 Head Fan is required
 Eden cannot guarantee performance of the Condensing Units if non-standard fan motors are used.

POLAPAK Low Temperature Series
Performance Data
Capacity(kW)

R404A/R507A 
50Hz

Compressor Model	Nominal Power (HP)	Ambient Temperature (°C)	SCT (°C)	Refrigerating Capacity Qo(kW) Power Input Pe(kW)				
				Evaporating Temperature (°C)				
				-25	-30	-35	-40	
PLB6G34.1625R.54T	34	35	41	Qo	38.20	30.00	23.10	17.29
				Pe	21.20	18.57	15.98	13.49
		38	44	Qo	36.10	28.30	21.70	16.19
				Pe	21.60	18.86	16.15	13.55
		41	47	Qo	34.00	26.60	20.30	15.07
				Pe	22.00	19.12	16.27	13.57
PLB6F44.1288R.54	44	35	44	Qo	42.90	33.50	25.40	18.54
				Pe	26.10	22.70	19.35	16.10
		38	47	Qo	40.40	31.40	23.70	17.11
				Pe	26.40	22.80	19.35	15.98
		41	50	Qo	37.80	29.20	21.90	15.66
				Pe	26.60	22.90	19.30	15.80
PLB6F44.2030R.63T	44	35	41	Qo	45.50	35.60	27.10	19.97
				Pe	25.70	22.50	19.29	16.18
		38	44	Qo	42.90	33.50	25.40	18.54
				Pe	26.10	22.70	19.35	16.10
		41	47	Qo	40.40	31.40	23.70	17.11
				Pe	26.40	22.80	19.35	15.98

Compressor Model	Nominal Power (HP)	Ambient Temperature (°C)	SCT (°C)	Refrigerating Capacity Qo(kW) Power Input Pe(kW)				
				Evaporating Temperature (°C)				
				-25*	-30*	-35	-40	
PSB4T05.0337S.51	5	35	44	Qo	8.88	7.25	5.99	4.88
				Pe	5.35	4.95	4.55	4.12
		38	47	Qo	8.59	7.17	5.92	4.83
				Pe	5.53	5.12	4.69	4.25
		41	50	Qo	8.49	7.09	5.86	4.77
				Pe	5.72	5.28	4.83	4.38
PSB4T05.0412S.61T	5	35	41	Qo	8.79	7.34	6.06	4.94
				Pe	5.16	4.79	4.40	4.00
		38	44	Qo	8.88	7.25	5.99	4.88
				Pe	5.35	4.95	4.55	4.12
		41	47	Qo	8.59	7.17	5.92	4.83
				Pe	5.53	5.12	4.69	4.25
PSB4N08.0376S.51	8	35	44	Qo	12.29	10.29	8.51	6.95
				Pe	7.66	7.08	6.49	5.89
		38	47	Qo	12.14	10.16	8.41	6.87
				Pe	7.91	7.31	6.70	6.07
		41	50	Qo	11.98	10.04	8.31	6.79
				Pe	8.17	7.54	6.90	6.26
PSB4N08.0653R.52T	8	35	41	Qo	12.44	10.41	8.61	7.03
				Pe	7.40	6.86	6.29	5.71
		38	44	Qo	12.29	10.29	8.51	6.95
				Pe	7.66	7.08	6.49	5.89
		41	47	Qo	12.14	10.16	8.41	6.87
				Pe	7.91	7.31	6.70	6.07
PSB4G12.0653R.52	12	35	44	Qo	18.59	15.93	13.42	11.12
				Pe	11.57	10.70	9.79	8.86
		38	47	Qo	18.33	15.69	13.23	10.98
				Pe	11.95	11.05	10.11	9.15
		41	50	Qo	18.06	15.46	13.05	10.84
				Pe	12.32	11.40	10.44	9.44

Capacity based on 20°C Suction Temperature with no Sub-Cooling(PLB6G34.1625R.54T to PLB6F44.2030R.63T)
 Capacity based on 20°C Suction Temperature with Sub-Cooling (PSB4T050.0337S.51 to PSB4G120.0653R.52)
 Head Fan is required
 Eden cannot guarantee performance of the Condensing Units if non-standard fan motors are used.

POLAPAK Low Temperature Series
Performance Data
Capacity(kW)

R404A/R507A 
50Hz

Compressor Model	Nominal Power (HP)	Ambient Temperature (°C)	SCT (°C)	Refrigerating Capacity Qo(kW) Power Input Pe(kW)					
				Evaporating Temperature (°C)				Qo	Pe
				-25*	-30*	-35	-40		
PSB4G12.0905R.53T	12	35	41	Qo	18.84	16.15	13.62	11.28	
				Pe	11.18	10.35	9.48	8.58	
		38	44	Qo	18.59	15.93	13.42	11.12	
				Pe	11.57	10.70	9.79	8.86	
		41	47	Qo	18.33	15.69	13.23	10.98	
				Pe	11.95	11.05	10.11	9.15	
PSB6J16.0861R.52	16	35	44	Qo	26.10	22.40	18.99	15.82	
				Pe	16.76	15.25	13.81	12.42	
		38	47	Qo	25.80	22.10	18.74	15.62	
				Pe	17.31	15.75	14.25	12.82	
		41	50	Qo	25.50	21.90	18.50	15.43	
				Pe	17.83	16.23	14.68	13.20	
PSB6J16.1158R.53T	16	35	41	Qo	26.40	22.70	19.24	16.03	
				Pe	16.19	14.75	13.36	12.03	
		38	44	Qo	26.10	22.40	18.99	15.82	
				Pe	16.76	15.25	13.81	12.42	
		41	47	Qo	25.80	22.10	18.74	15.62	
				Pe	17.31	15.75	14.25	12.82	
PSB6H20.0905R.53	20	35	44	Qo	30.00	25.90	21.90	18.27	
				Pe	19.38	17.66	16.00	14.40	
		38	47	Qo	29.60	25.50	21.60	18.02	
				Pe	20.00	18.23	16.50	14.85	
		41	50	Qo	29.30	25.20	21.30	17.79	
				Pe	20.60	18.79	17.01	15.30	
PSB6H20.1432R.54T	20	35	41	Qo	30.40	26.20	22.20	18.51	
				Pe	18.75	17.09	15.49	13.94	
		38	44	Qo	30.00	25.90	21.90	18.27	
				Pe	19.38	17.66	16.00	14.40	
		41	47	Qo	29.60	25.50	21.60	18.02	
				Pe	20.00	18.23	16.50	14.85	
PSB6G25.1088R.53	25	35	44	Qo	34.30	29.50	25.00	20.90	
				Pe	22.30	20.30	18.37	16.53	
		38	47	Qo	33.80	29.10	24.70	20.60	
				Pe	23.00	20.90	18.95	17.04	
		41	50	Qo	33.40	28.70	24.30	20.30	
				Pe	23.70	21.60	19.53	17.56	
PSB6G25.1625R.54T	25	35	41	Qo	34.70	29.90	25.40	21.20	
				Pe	21.50	19.62	17.79	16.02	
		38	44	Qo	34.30	29.50	25.00	20.90	
				Pe	22.30	20.30	18.37	16.53	
		41	47	Qo	33.80	29.10	24.70	20.60	
				Pe	23.00	20.90	18.95	17.04	
PSB6F30.1288R.54	30	35	44	Qo	40.60	35.00	29.70	24.80	
				Pe	26.30	24.10	21.90	19.78	
		38	47	Qo	40.00	34.50	29.20	24.40	
				Pe	27.20	24.90	22.60	20.40	
		41	50	Qo	39.50	34.00	28.80	24.10	
				Pe	28.10	25.70	23.30	21.00	
PSB6F30.1890R.63T	30	35	41	Qo	41.20	35.50	30.10	25.10	
				Pe	25.50	23.40	21.20	19.16	
		38	44	Qo	40.60	35.00	29.70	24.80	
				Pe	26.30	24.10	21.90	19.78	
		41	47	Qo	40.00	34.50	29.20	24.40	
				Pe	27.20	24.90	22.60	20.40	

Capacity based on 20°C Suction Temperature with Sub-Cooling
 Eden cannot guarantee performance of the Condensing Units if non-standard fan motors are used.

POLAPAK Low Temperature Series

Performance Data

Capacity(kW)

R22A  +5°C
-25°C
-40°C

50Hz

Compressor Model	Nominal Power (HP)	Ambient Temperature (°C)	SCT (°C)	Refrigerating Capacity Qo(kW) Power Input Pe(kW)				
				Evaporating Temperature (°C)				-40
				-25	-30	-35	-40	
PLB2KA5.0054B.21	0.5	35	44	Qo	0.79	0.59	0.43	0.30
				Pe	0.59	0.49	0.40	0.31
		38	47	Qo	0.74	0.55	0.40	0.28
				Pe	0.60	0.50	0.40	0.31
		41	50	Qo	0.70	0.51	0.37	-
				Pe	0.61	0.50	0.40	-
PLB2KA5.0064B.21T	0.5	35	41	Qo	0.84	0.63	0.46	0.33
				Pe	0.58	0.49	0.40	0.31
		38	44	Qo	0.79	0.59	0.43	0.30
				Pe	0.59	0.49	0.40	0.31
		41	47	Qo	0.74	0.55	0.40	0.28
				Pe	0.60	0.50	0.40	0.31
PLB2JA7.0054B.21	0.7	35	44	Qo	1.10	0.82	0.60	0.41
				Pe	0.79	0.68	0.57	0.45
		38	47	Qo	1.04	0.77	0.55	0.38
				Pe	0.80	0.68	0.57	0.44
		41	50	Qo	0.98	0.72	0.51	-
				Pe	0.81	0.69	0.56	-
PLB2JA7.0064B.21T	0.7	35	41	Qo	1.17	0.88	0.64	0.45
				Pe	0.77	0.67	0.56	0.45
		38	44	Qo	1.10	0.82	0.60	0.41
				Pe	0.79	0.68	0.57	0.45
		41	47	Qo	1.04	0.77	0.55	0.38
				Pe	0.80	0.68	0.57	0.44
PLB2H01.0054B.21	1	35	44	Qo	1.51	1.14	0.83	0.56
				Pe	1.01	0.86	0.70	0.54
		38	47	Qo	1.44	1.08	0.77	0.52
				Pe	1.03	0.87	0.71	0.54
		41	50	Qo	1.38	1.01	0.72	-
				Pe	1.08	0.89	0.71	-
PLB2H01.0090B.31T	1	35	41	Qo	1.59	1.20	0.88	0.61
				Pe	0.99	0.85	0.70	0.54
		38	44	Qo	1.51	1.14	0.83	0.56
				Pe	1.01	0.86	0.70	0.54
		41	47	Qo	1.44	1.08	0.77	0.52
				Pe	1.03	0.87	0.71	0.54
PLB2G02.0064B.21	2	35	44	Qo	1.83	1.40	1.03	0.73
				Pe	1.24	1.08	0.91	0.72
		38	47	Qo	1.74	1.32	0.97	0.67
				Pe	1.26	1.09	0.91	0.71
		41	50	Qo	1.65	1.24	0.90	-
				Pe	1.28	1.10	0.91	-
PLB2G02.0110B.31T	2	35	41	Qo	1.93	1.48	1.10	0.79
				Pe	1.22	1.07	0.91	0.73
		38	44	Qo	1.83	1.40	1.03	0.73
				Pe	1.24	1.08	0.91	0.72
		41	47	Qo	1.74	1.32	0.97	0.67
				Pe	1.26	1.09	0.91	0.71
PLB2F02.0090B.31	2	35	44	Qo	2.24	1.71	1.28	0.92
				Pe	1.44	1.25	1.05	0.85
		38	47	Qo	2.12	1.61	1.19	0.85
				Pe	1.46	1.25	1.04	0.84
		41	50	Qo	1.99	1.51	1.11	-
				Pe	1.48	1.26	1.04	-

Capacity based on 20°C Suction Temperature with no Sub-Cooling
Head Fan is required
Eden cannot guarantee performance of the Condensing Units if non-standard fan motors are used

POLAPAK Low Temperature Series
Performance Data
Capacity(kW)

R22A  +5°C
 -25°C
 -40°C
50Hz

Compressor Model	Nominal Power (HP)	Ambient Temperature (°C)	SCT (°C)	Refrigerating Capacity Qo(kW) Power Input Pe(kW)				
				Evaporating Temperature (°C)				
				-25	-30	-35	-40	
PLB2F02.0128B.31T	2	35	41	Qo	2.36	1.82	1.37	0.99
				Pe	1.42	1.23	1.05	0.86
		38	44	Qo	2.24	1.71	1.28	0.92
				Pe	1.44	1.25	1.05	0.85
		41	47	Qo	2.12	1.61	1.19	0.85
				Pe	1.46	1.25	1.04	0.84
PLB2E02.0110B.31	2	35	44	Qo	2.68	2.00	1.42	0.94
				Pe	1.63	1.39	1.14	0.90
		38	47	Qo	2.54	1.88	1.32	0.86
				Pe	1.66	1.41	1.15	0.90
		41	50	Qo	2.41	1.77	1.24	-
				Pe	1.70	1.43	1.16	-
PLB2E02.0138B.41T	2	35	41	Qo	2.82	2.12	1.52	1.02
				Pe	1.60	1.37	1.14	0.90
		38	44	Qo	2.68	2.00	1.42	0.94
				Pe	1.63	1.39	1.14	0.90
		41	47	Qo	2.54	1.88	1.32	0.86
				Pe	1.66	1.41	1.15	0.90
PLB2D02.0128B.31	2	35	44	Qo	3.24	2.43	1.75	1.18
				Pe	2.00	1.71	1.42	1.13
		38	47	Qo	3.09	2.30	1.64	1.08
				Pe	2.04	1.74	1.43	1.13
		41	50	Qo	2.93	2.18	1.54	-
				Pe	2.09	1.77	1.45	-
PLB2D02.0187B.41T	2	35	41	Qo	3.41	2.57	1.86	1.27
				Pe	1.95	1.68	1.40	1.13
		38	44	Qo	3.24	2.43	1.75	1.18
				Pe	2.00	1.71	1.42	1.13
		41	47	Qo	3.09	2.30	1.64	1.08
				Pe	2.04	1.74	1.43	1.13
PLB2C03.0138B.41	3	35	44	Qo	4.07	3.08	2.25	1.55
				Pe	2.48	2.15	1.81	1.47
		38	47	Qo	3.88	2.93	2.12	1.44
				Pe	2.55	2.19	1.84	1.49
		41	50	Qo	3.71	2.78	2.00	-
				Pe	2.62	2.24	1.87	-
PLB2C03.0227S.51T	3	35	41	Qo	4.27	3.25	2.38	1.66
				Pe	2.42	2.10	1.78	1.46
		38	44	Qo	4.07	3.08	2.25	1.55
				Pe	2.48	2.15	1.81	1.47
		41	47	Qo	3.88	2.93	2.12	1.44
				Pe	2.55	2.19	1.84	1.49
PLB4F03.0138B.41	3	35	44	Qo	4.16	3.09	2.19	1.45
				Pe	2.53	2.15	1.77	1.39
		38	47	Qo	3.94	2.90	2.04	1.33
				Pe	2.57	2.18	1.78	1.39
		41	50	Qo	3.73	2.73	1.90	-
				Pe	2.62	2.20	1.78	-
PLB4F03.0280S.51T	3	35	41	Qo	4.39	3.28	2.35	1.59
				Pe	2.48	2.12	1.76	1.40
		38	44	Qo	4.16	3.09	2.19	1.45
				Pe	2.53	2.15	1.77	1.39
		41	47	Qo	3.94	2.90	2.04	1.33
				Pe	2.57	2.18	1.78	1.39

Capacity based on 20°C Suction Temperature with no Sub-Cooling
 Head Fan is required
 Eden cannot guarantee performance of the Condensing Units If non-standard fan motors are used

POLAPAK Low Temperature Series

Performance Data

Capacity(kW)

R22A  +5°C
-25°C
-40°C

50Hz

Compressor Model	Nominal Power (HP)	Ambient Temperature (°C)	SCT (°C)	Refrigerating Capacity Qo(kW) Power Input Pe(kW)					
				Evaporating Temperature (°C)				Qo	Pe
				-25	-30	-35	-40		
PLB4E04.0227S.51	4	35	44	Qo	5.35	4.00	2.87	1.93	
				Pe	3.22	2.73	2.25	1.77	
		38	47	Qo	5.08	3.77	2.68	1.77	
				Pe	3.29	2.78	2.27	1.77	
		41	50	Qo	4.81	3.56	2.50	-	
				Pe	3.36	2.82	2.29	-	
PLB4E04.0337S.51T	4	35	41	Qo	5.64	4.24	3.07	2.09	
				Pe	3.15	2.69	2.23	1.77	
		38	44	Qo	5.35	4.00	2.87	1.93	
				Pe	3.22	2.73	2.25	1.77	
		41	47	Qo	5.08	3.77	2.68	1.77	
				Pe	3.29	2.78	2.27	1.77	
PLB4D05.0227S.51	5	35	44	Qo	6.48	4.87	3.52	2.41	
				Pe	3.90	3.34	2.79	2.24	
		38	47	Qo	6.16	4.60	3.30	2.23	
				Pe	3.99	3.40	2.82	2.26	
		41	50	Qo	5.85	4.35	3.10	-	
				Pe	4.08	3.47	2.86	-	
PLB4D05.0376S.51T	5	35	41	Qo	6.82	5.15	3.76	2.60	
				Pe	3.81	3.29	2.76	2.23	
		38	44	Qo	6.48	4.87	3.52	2.41	
				Pe	3.90	3.34	2.79	2.24	
		41	47	Qo	6.16	4.60	3.30	2.23	
				Pe	3.99	3.40	2.82	2.26	
PLB4C06.0280S.51	6	35	44	Qo	8.13	6.17	4.52	3.15	
				Pe	4.87	4.22	3.57	2.93	
		38	47	Qo	7.75	5.86	4.27	2.94	
				Pe	4.99	4.31	3.63	2.98	
		41	50	Qo	7.39	5.56	4.02	-	
				Pe	5.12	4.41	3.70	-	
PLB4C06.0412S.61T	6	35	41	Qo	8.53	6.51	4.80	3.38	
				Pe	4.74	4.13	3.51	2.90	
		38	44	Qo	8.13	6.17	4.52	3.15	
				Pe	4.87	4.22	3.57	2.93	
		41	47	Qo	7.75	5.86	4.27	2.94	
				Pe	4.99	4.31	3.63	2.98	
PLB4V07.0337S.51	7	35	44	Qo	8.29	6.17	4.37	2.87	
				Pe	4.79	4.12	3.41	2.65	
		38	47	Qo	7.80	5.74	4.01	2.56	
				Pe	4.85	4.14	3.39	2.58	
		41	50	Qo	7.32	5.34	3.67	2.28	
				Pe	4.90	4.13	3.33	2.49	
PLB4V07.0412S.61T	7	35	41	Qo	8.58	6.59	4.73	3.18	
				Pe	4.60	4.08	3.41	2.68	
		38	44	Qo	8.29	6.17	4.37	2.87	
				Pe	4.79	4.12	3.41	2.65	
		41	47	Qo	7.80	5.74	4.01	2.56	
				Pe	4.85	4.14	3.39	2.58	
PLB4T09.0337S.51	9	35	44	Qo	10.14	7.56	5.38	3.55	
				Pe	5.92	5.18	4.39	3.53	
		38	47	Qo	9.59	7.09	4.99	3.23	
				Pe	6.02	5.24	4.41	3.51	
		41	50	Qo	9.05	6.64	4.61	2.91	
				Pe	6.09	5.25	4.37	3.43	

Capacity based on 20°C Suction Temperature with no Sub-Cooling
 Head Fan is required CIC is required
 Eden cannot guarantee performance of the Condensing Units if non-standard fan motors are used

POLAPAK Low Temperature Series
Performance Data
Capacity(kW)

R22A 
50Hz

Compressor Model	Nominal Power (HP)	Ambient Temperature (°C)	SCT (°C)	Refrigerating Capacity Qo(kW) Power Input Pe(kW)					
				Evaporating Temperature (°C)				Qo	Pe
				-25	-30	-35	-40		
PLB4T09.0524S.61T	9	35	41	Qo	10.54	8.04	5.78	3.90	
				Pe	5.67	5.09	4.34	3.52	
		38	44	Qo	10.14	7.56	5.38	3.55	
				Pe	5.92	5.18	4.39	3.53	
		41	47	Qo	9.59	7.09	4.99	3.23	
				Pe	6.02	5.24	4.41	3.51	
PLB4P12.0376S.51	12	35	44	Qo	11.77	8.77	6.23	4.11	
				Pe	6.70	5.77	4.87	4.03	
		38	47	Qo	11.13	8.23	5.78	3.72	
				Pe	6.81	5.83	4.90	4.04	
		41	50	Qo	10.50	7.70	5.33	3.35	
				Pe	6.91	5.89	4.93	4.04	
PLB4P12.0564S.61T	12	35	41	Qo	11.74	9.31	6.69	4.50	
				Pe	6.21	5.71	4.84	4.02	
		38	44	Qo	11.77	8.77	6.23	4.11	
				Pe	6.70	5.77	4.87	4.03	
		41	47	Qo	11.13	8.23	5.78	3.72	
				Pe	6.81	5.83	4.90	4.04	
PLB4N14.0412S.61	14	35	44	Qo	13.73	10.22	7.27	4.81	
				Pe	7.83	6.78	5.76	4.80	
		38	47	Qo	13.00	9.60	6.73	4.35	
				Pe	7.96	6.86	5.80	4.82	
		41	50	Qo	12.27	8.98	6.20	3.88	
				Pe	8.09	6.94	5.84	4.81	
PLB4N14.0653R.52T	14	35	41	Qo	14.11	10.84	7.79	5.26	
				Pe	7.54	6.69	5.70	4.77	
		38	44	Qo	13.73	10.22	7.27	4.81	
				Pe	7.83	6.78	5.76	4.80	
		41	47	Qo	13.00	9.60	6.73	4.35	
				Pe	7.96	6.86	5.80	4.82	
PLB4J15.0524S.61	15	35	44	Qo	15.06	11.08	7.75	4.98	
				Pe	8.90	7.64	6.36	5.04	
		38	47	Qo	14.33	10.48	7.27	4.61	
				Pe	9.11	7.78	6.42	5.02	
		41	50	Qo	13.62	9.92	6.83	4.28	
				Pe	9.35	7.94	6.50	4.99	
PLB4J15.0861R.52T	15	35	41	Qo	16.37	11.71	8.27	5.40	
				Pe	8.69	7.51	6.31	5.07	
		38	44	Qo	15.06	11.08	7.75	4.98	
				Pe	8.90	7.64	6.36	5.04	
		41	47	Qo	14.33	10.48	7.27	4.61	
				Pe	9.11	7.78	6.42	5.02	
PLB4H18.0653R.52	18	35	44	Qo	17.46	12.85	8.99	5.78	
				Pe	10.33	8.87	7.38	5.86	
		38	47	Qo	16.61	12.15	8.43	5.35	
				Pe	10.59	9.03	7.45	5.82	
		41	50	Qo	15.79	11.50	7.91	4.96	
				Pe	10.86	9.22	7.54	5.80	
PLB4H18.0905R.53T	18	35	41	Qo	19.11	13.59	9.59	6.26	
				Pe	10.15	8.72	7.33	5.90	
		38	44	Qo	17.46	12.85	8.99	5.78	
				Pe	10.33	8.87	7.38	5.86	
		41	47	Qo	16.61	12.15	8.43	5.35	
				Pe	10.59	9.03	7.45	5.82	

Capacity based on 20°C Suction Temperature with no Sub-Cooling
 Head Fan is required  CIC is required
 Eden cannot guarantee performance of the Condensing Units if non-standard fan motors are used

POLAPAK Low Temperature Series

Performance Data

Capacity(kW)

R22A  +5°C
-25°C
-40°C

50Hz

Compressor Model	Nominal Power (HP)	Ambient Temperature (°C)	SCT (°C)	Refrigerating Capacity Qo(kW) Power Input Pe(kW)				
				Evaporating Temperature (°C)				
				-25	-30	-35	-40	
PLB4G23.0760R.52	23	35	44	Qo	20.20	14.94	10.48	6.75
				Pe	12.37	10.68	8.91	7.11
		38	47	Qo	19.28	14.14	9.83	6.24
				Pe	12.75	10.95	9.04	7.08
		41	50	Qo	18.34	13.38	9.23	5.79
				Pe	13.15	11.24	9.20	7.06
PLB4G23.1088R.53T	23	35	41	Qo	23.10	15.78	11.18	7.32
				Pe	12.36	10.44	8.80	7.13
		38	44	Qo	20.20	14.94	10.48	6.75
				Pe	12.37	10.68	8.91	7.11
		41	47	Qo	19.28	14.14	9.83	6.24
				Pe	12.75	10.95	9.04	7.08
PLB4F28.0861R.52	28	35	44	Qo	24.20	17.86	12.53	8.07
				Pe	14.79	12.77	10.65	8.50
		38	47	Qo	23.00	16.90	11.75	7.46
				Pe	15.24	13.08	10.81	8.47
		41	50	Qo	21.90	16.00	11.03	6.92
				Pe	15.72	13.44	11.00	8.44
PLB4F28.1288R.54T	28	35	41	Qo	27.60	18.87	13.36	8.75
				Pe	14.62	12.48	10.51	8.53
		38	44	Qo	24.20	17.86	12.53	8.07
				Pe	14.79	12.77	10.65	8.50
		41	47	Qo	23.00	16.90	11.75	7.46
				Pe	15.24	13.08	10.81	8.47
PLB6J25.0760R.52	25	35	44	Qo	22.60	16.62	11.62	7.48
				Pe	13.35	11.46	9.53	7.55
		38	47	Qo	21.50	15.72	10.90	6.91
				Pe	13.68	11.68	9.81	7.50
		41	50	Qo	20.40	14.87	10.24	6.42
				Pe	14.04	11.91	9.73	7.47
PLB6J25.1088R.53T	25	35	41	Qo	24.60	17.57	12.41	8.10
				Pe	12.97	11.27	9.46	7.60
		38	44	Qo	22.60	16.62	11.62	7.48
				Pe	13.35	11.46	9.53	7.55
		41	47	Qo	21.50	15.72	10.90	6.91
				Pe	13.68	11.68	9.81	7.50
PLB6H28.0861R.52	28	35	44	Qo	26.20	19.27	13.48	8.67
				Pe	15.49	13.30	11.05	8.76
		38	47	Qo	24.90	18.22	12.64	8.01
				Pe	15.87	13.54	11.14	8.70
		41	50	Qo	23.70	17.24	11.87	7.44
				Pe	16.28	13.81	11.27	8.66
PLB6H28.1432R.54T	28	35	41	Qo	29.40	20.40	14.39	9.40
				Pe	15.62	13.08	10.98	8.83
		38	44	Qo	26.20	19.27	13.48	8.67
				Pe	15.49	13.30	11.05	8.76
		41	47	Qo	24.90	18.22	12.64	8.01
				Pe	15.87	13.54	11.14	8.70
PLB6G34.1088R.53	34	35	44	Qo	30.40	22.40	15.72	10.13
				Pe	18.54	16.00	13.34	10.65
		38	47	Qo	28.90	21.20	14.74	9.36
				Pe	19.10	16.40	13.55	10.62
		41	50	Qo	27.50	20.10	13.84	8.68
				Pe	19.71	16.85	13.79	10.59



Capacity based on 20°C Suction Temperature with no Sub-Cooling
 Head Fan is required ■ CIC is required
 Eden cannot guarantee performance of the Condensing Units if non-standard fan motors are used

POLAPAK Low Temperature Series
Performance Data
Capacity(kW)

R22A 
50Hz

Compressor Model	Nominal Power (HP)	Ambient Temperature (°C)	SCT (°C)	Refrigerating Capacity Qo(kW) Power Input Pe(kW)				
				Evaporating Temperature (°C)				
				-25	-30	-35	-40	
PLB6G34.1625R.54T	34	35	41	Qo	34.10	23.70	16.77	10.99
				Pe	18.17	15.62	13.16	10.68
		38	44	Qo	30.40	22.40	15.72	10.13
				Pe	18.54	16.00	13.34	10.65
		41	47	Qo	28.90	21.20	14.74	9.36
				Pe	19.10	16.40	13.55	10.62
PLB6F44.1288R.54	44	35	44	Qo	36.60	27.20	19.26	12.61
				Pe	22.40	19.26	16.11	13.00
		38	47	Qo	34.90	25.80	18.11	11.69
				Pe	23.10	19.74	16.35	12.95
		41	50	Qo	33.30	24.50	17.07	10.89
				Pe	23.70	20.20	16.60	12.94
PLB6F44.2030R.63T	44	35	41	Qo	41.40	28.60	20.50	13.61
				Pe	22.20	18.78	15.88	13.04
		38	44	Qo	36.60	27.20	19.26	12.61
				Pe	22.40	19.26	16.11	13.00
		41	47	Qo	34.90	25.80	18.11	11.69
				Pe	23.10	19.74	16.35	12.95

Compressor Model	Nominal Power (HP)	Ambient Temperature (°C)	SCT (°C)	Refrigerating Capacity Qo(kW) Power Input Pe(kW)				
				Evaporating Temperature (°C)				
				-25*	-30*	-35	-40	
PSB4T05.0337S.51	5	35	44	Qo	7.79	6.37	5.13	4.05
				Pe	4.30	4.02	3.71	3.38
		38	47	Qo	7.72	6.32	5.09	4.01
				Pe	4.45	4.16	3.84	3.48
		41	50	Qo	7.66	6.27	5.05	3.98
				Pe	4.60	4.29	3.96	3.59
PSB4T05.0412S.61T	5	35	41	Qo	7.86	6.42	5.17	4.09
				Pe	4.15	3.88	3.59	3.27
		38	44	Qo	7.79	6.37	5.13	4.05
				Pe	4.30	4.02	3.71	3.38
		41	47	Qo	7.72	6.32	5.09	4.01
				Pe	4.45	4.16	3.84	3.48
PSB4N08.0376S.51	8	35	44	Qo	11.19	9.18	7.40	5.83
				Pe	6.56	6.05	5.54	5.03
		38	47	Qo	11.08	9.09	7.32	5.76
				Pe	6.80	6.26	5.73	5.19
		41	50	Qo	10.97	9.00	7.24	5.68
				Pe	7.03	6.47	5.91	5.35
PSB4N08.0653R.52T	8	35	41	Qo	11.30	9.27	7.48	5.91
				Pe	6.33	5.84	5.35	4.86
		38	44	Qo	11.19	9.18	7.40	5.83
				Pe	6.56	6.05	5.54	5.03
		41	47	Qo	11.08	9.09	7.32	5.76
				Pe	6.80	6.26	5.73	5.19
PSB4G12.0653R.52	12	35	44	Qo	16.91	13.87	11.18	8.81
				Pe	9.92	9.14	8.37	7.60
		38	47	Qo	16.74	13.73	11.06	8.70
				Pe	10.28	9.46	8.65	7.84
		41	50	Qo	16.57	13.59	10.94	8.58
				Pe	10.63	9.78	8.93	8.09

Capacity based on 20°C Suction Temperature with no Sub-Cooling(PLB6G34.1625R.54T-PLB6F44.2030R.63T)
 Capacity based on 20°C Suction Temperature with Sub-Cooling (PSB4T05.0337S.51-PSB4G12.0653R.52)
 Head Fan is required  CIC is required 
 Eden cannot guarantee performance of the Condensing Units if non-standard fan motors are used

POLAPAK Low Temperature Series
Performance Data
Capacity(kW)

R22A 
50Hz

Compressor Model	Nominal Power (HP)	Ambient Temperature (°C)	SCT (°C)	Refrigerating Capacity Qo(kW) Power Input Pe(kW)					
				Evaporating Temperature (°C)				Qo	Pe
				-25*	-30*	-35	-40		
PSB4G12.0905R.53T	12	35	41	Qo	17.08	14.01	11.31	8.93	
				Pe	9.56	8.82	8.08	7.35	
		38	44	Qo	16.91	13.87	11.18	8.81	
				Pe	9.92	9.14	8.37	7.60	
		41	47	Qo	16.74	13.73	11.06	8.70	
				Pe	10.28	9.46	8.65	7.84	
PSB6J16.0861R.52	16	35	44	Qo	24.90	20.60	16.75	13.29	
				Pe	14.56	13.20	11.84	10.48	
		38	47	Qo	24.70	20.50	16.65	13.21	
				Pe	15.05	13.63	12.21	10.77	
		41	50	Qo	24.60	20.40	16.57	13.13	
				Pe	15.53	14.05	12.56	11.05	
PSB6J16.1158R.53T	16	35	41	Qo	25.00	20.70	16.84	13.39	
				Pe	14.07	12.77	11.47	10.17	
		38	44	Qo	24.90	20.60	16.75	13.29	
				Pe	14.56	13.20	11.84	10.48	
		41	47	Qo	24.70	20.50	16.65	13.21	
				Pe	15.05	13.63	12.21	10.77	
PSB6H20.0905R.53	20	35	44	Qo	28.90	23.90	19.41	15.41	
				Pe	16.88	15.30	13.73	12.14	
		38	47	Qo	28.70	23.70	19.30	15.31	
				Pe	17.44	15.80	14.15	12.48	
		41	50	Qo	28.50	23.60	19.21	15.22	
				Pe	18.00	16.29	14.56	12.80	
PSB6H20.1432R.54T	20	35	41	Qo	29.00	24.00	19.52	15.52	
				Pe	16.31	14.80	13.30	11.79	
		38	44	Qo	28.90	23.90	19.41	15.41	
				Pe	16.88	15.30	13.73	12.14	
		41	47	Qo	28.70	23.70	19.30	15.31	
				Pe	17.44	15.80	14.15	12.48	
PSB6G25.1088R.53	25	35	44	Qo	33.10	27.40	22.30	17.69	
				Pe	19.38	17.57	15.76	13.94	
		38	47	Qo	32.90	27.20	22.20	17.58	
				Pe	20.00	18.14	16.25	14.33	
		41	50	Qo	32.70	27.10	22.10	17.47	
				Pe	20.70	18.70	16.72	14.70	
PSB6G25.1625R.54T	25	35	41	Qo	33.30	27.60	22.40	17.82	
				Pe	18.73	17.00	15.27	13.54	
		38	44	Qo	33.10	27.40	22.30	17.69	
				Pe	19.38	17.57	15.76	13.94	
		41	47	Qo	32.90	27.20	22.20	17.58	
				Pe	20.00	18.14	16.25	14.33	
PSB6F30.1288R.54	30	35	44	Qo	39.60	32.80	26.70	21.20	
				Pe	23.20	21.00	18.86	16.68	
		38	47	Qo	39.40	32.60	26.50	21.00	
				Pe	24.00	21.70	19.44	17.15	
		41	50	Qo	39.20	32.40	26.40	20.90	
				Pe	24.70	22.40	20.00	17.59	
PSB6F30.1890R.63T	30	35	41	Qo	39.90	33.00	26.80	21.30	
				Pe	22.40	20.30	18.27	16.19	
		38	44	Qo	39.60	32.80	26.70	21.20	
				Pe	23.20	21.00	18.86	16.68	
		41	47	Qo	39.40	32.60	26.50	21.00	
				Pe	24.00	21.70	19.44	17.15	

Capacity based on 20°C Suction Temperature with Sub-Cooling
 Eden cannot guarantee performance of the Condensing Units if non-standard fan motors are used

Technical Data

Unit Model	Compressor Model	Nominal Input Rating (HP)	No. of Fans	Fan Diameter (mm)	Fan Motor Rating (W)	Fan Motor Current(A)	Receiver (L)	Liquid Line (Inch)	Suction Line (Inch)	Compressor		
										(V/Ph/Hz)	LRA (A)	MCC (A)
PMB2KA5.0054B.21	2KES-05	0.5	1	300	100	0.44	3	3/8	5/8	380.420V 3P/50Hz	12.0	2.8
PMB2KA5.0090B.31T	2KES-05	0.5	1	350	210	0.95	3	3/8	5/8		12.0	2.8
PMB2JA7.0090B.31	2JES-07	0.7	1	350	210	0.95	3	3/8	5/8		14.8	3.7
PMB2JA7.0110B.31T	2JES-07	0.7	1	350	210	0.95	3	3/8	5/8		14.8	3.7
PMB2H02.0090B.31	2HES-2	2	1	350	210	0.95	3	3/8	5/8		22.5	4.5
PMB2H02.0128B.31	2HES-2	2	1	350	210	0.95	3	3/8	5/8		22.5	4.5
PMB2G02.0110B.31	2GES-2	2	1	350	210	0.95	3	3/8	5/8		22.5	5.0
PMB2G02.0138B.41T	2GES-2	2	1	400	190	0.50	3	3/8	5/8		22.5	5.0
PMB2F03.0128B.31	2FES-3	3	1	350	210	0.95	6	3/8	5/8		25.5	6.1
PMB2F03.0187B.41T	2FES-3	3	1	400	190	0.50	6	3/8	5/8		25.5	6.1
PMB2E03.0187B.41	2EES-3	3	1	400	190	0.50	6	1/2	7/8		37.0	7.5
PMB2E03.0227S.51T	2EES-3	3	1	500	750	1.50	6	1/2	7/8		37.0	7.5
PMB2D03.0227S.51	2DES-3	3	1	500	750	1.50	6	1/2	7/8		37.0	8.6
PMB2D03.0280S.51T	2DES-3	3	1	500	750	1.50	6	1/2	7/8		37.0	8.6
PMB2C04.0280S.51	2CES-4	4	1	500	750	1.50	6	1/2	7/8		44.2	10.0
PMB2C04.0337S.51T	2CES-4	4	1	500	750	1.50	6	1/2	7/8		44.2	10.0
PMB4F05.0280S.51	4FES-5	5	1	500	750	1.50	8	1/2	7/8		62.2	10.8
PMB4F05.0378S.51T	4FES-5	5	1	500	750	1.50	8	1/2	7/8		62.2	10.8
PMB4E06.0337S.51	4EES-6	6	1	500	750	1.50	8	1/2	1-1/8		62.2	13.6
PMB4E06.0486S.61T	4EES-6	6	1	630	850	1.80	8	1/2	1-1/8		62.2	13.6
PMB4D07.0412S.61	4DES-7	7	1	630	850	1.80	13	5/8	1-1/8		82.4	16.5
PMB4D07.0564S.61T	4DES-7	7	1	630	850	1.80	13	5/8	1-1/8		82.4	16.5
PMB4C09.0524S.61	4CES-9	9	1	630	850	1.80	13	5/8	1-1/8		82.4	20.2
PMB4C09.0760R.52T	4CES-9	9	2	500	1500	3.00	13	5/8	1-1/8		82.4	20.2
PMB4V10.0524S.61	4VES-10	10	1	630	850	1.80	13	5/8	1-1/8		99.0	19.9
PMB4V10.0760R.52T	4VES-10	10	2	500	1500	3.00	13	5/8	1-1/8		99.0	19.9
PMB4T12.0853R.52	4TES-12	12	2	500	1500	3.00	15	5/8	1-3/8		113.0	25.1
PMB4T12.0881R.52T	4TES-12	12	2	500	1500	3.00	15	5/8	1-3/8		113.0	25.1
PMB4P15.0760R.52	4PES-15	15	2	500	1500	3.00	30	7/8	1-5/8		132.0	28.2
PMB4P15.1038R.53T	4PES-15	15	3	500	2250	4.50	30	7/8	1-5/8		132.0	28.2
PMB4N20.0881R.52	4NES-20	20	2	500	1500	3.00	30	7/8	1-5/8		158.0	33.2
PMB4N20.1158R.53T	4NES-20	20	3	500	2250	4.50	30	7/8	1-5/8		158.0	33.2
PMB4J22.1038R.53	4JE-22	22	3	500	2250	4.50	30	7/8	1-5/8		158.0	37.2
PMB4J22.1288R.54T	4JE-22	22	4	500	3000	6.00	30	7/8	1-5/8		158.0	37.2
PMB4H25.1088R.53	4HE-25	25	3	500	2250	4.50	30	7/8	2-1/8		211.0	44.0
PMB4H25.1540R.54T	4HE-25	25	4	500	3160	7.40	30	7/8	2-1/8		211.0	44.0
PMB4G30.1260R.53	4GE-30	30	3	500	2370	5.55	40	7/8	2-1/8		233.0	51.2
PMB4G30.1707R.53T	4GE-30	30	3	500	2370	5.55	40	7/8	2-1/8		233.0	51.2
PMB4F35.1540R.54	4FE-35	35	4	500	3160	7.40	40	7/8	2-1/8		233.0	62.1
PMB4F35.2030R.63T	4FE-35	35	3	630	1980	3.90	40	7/8	2-1/8		233.0	62.1
PMB6J33.1385R.54	6JE-33	33	4	500	3160	7.40	40	7/8	2-1/8		275.0	53.2
PMB6J33.1890R.63T	6JE-33	33	3	630	1980	3.90	40	7/8	2-1/8		275.0	53.2
PMB6H35.1625R.54	6HE-35	35	4	500	3160	7.40	40	1-1/8	2-1/8	275.0	64.4	
PMB6H35.2254R.64T	6HE-35	35	4	630	2640	5.20	40	1-1/8	2-1/8	275.0	64.4	
PMB6G40.1890R.63	6GE-40	40	3	630	1980	3.90	55	1-1/8	2-1/8	362.0	73.9	
PMB6G40.2500R.64T	6GE-40	40	4	630	2640	5.20	55	1-1/8	2-1/8	362.0	73.9	
PMB6F50.2254R.64	6FE-50	50	4	630	2640	5.20	55	1-1/8	2-1/8	404.0	96.2	
PMB6G60.2650R.64	6GE-60	60	4	630	2640	5.20	100	1-1/8	3-1/8	513.0	113.0	
PLB2KA5.0054B.21	2KES-05	0.5	1	300	100	0.44	3	3/8	5/8	12.0	2.8	
PLB2KA5.0084B.21T	2KES-05	0.5	1	300	100	0.44	3	3/8	5/8	12.0	2.8	
PLB2JA7.0054B.21	2JES-07	0.7	1	300	100	0.44	3	3/8	5/8	14.8	3.7	
PLB2JA7.0064B.21T	2JES-07	0.7	1	300	100	0.44	3	3/8	5/8	14.8	3.7	
PLB2H01.0054B.21	2HES-1	1	1	300	100	0.44	3	3/8	5/8	16.7	3.8	
PLB2H01.0090B.31T	2HES-1	1	1	350	210	0.95	3	3/8	5/8	16.7	3.8	
PLB2G02.0064B.21	2GES-2	2	1	300	100	0.44	3	3/8	5/8	22.5	5.0	
PLB2G02.0110B.31	2GES-2	2	1	350	210	0.95	3	3/8	5/8	22.5	5.0	
PLB2F02.0090B.31	2FES-2	2	1	350	210	0.95	3	3/8	5/8	22.5	5.3	
PLB2F02.0128B.31T	2FES-2	2	1	350	210	0.95	3	3/8	5/8	22.5	5.3	

All 300mm and 350mm Fan Motor models are 230V/1Ph/50Hz and all others are 400V/3Ph/50Hz.
Condensers are remote

Technical Data

Unit Model	Compressor Model	Nominal Input Rating (HP)	No. of Fans	Fan Diameter (mm)	Fan Motor Rating (W)	Fan Motor Current(A)	Receiver (L)	Liquid Line (Inch)	Suction Line (Inch)	Compressor		
										(V/Ph/Hz)	LRA (A)	MCC (A)
PLB2E02.0110B.31	2EES-2	2	1	350	210	0.95	3	3/8	7/8	380..420V 3P/50Hz	26.0	6.0
PLB2E02.0138B.41T	2EES-2	2	1	400	190	0.50	3	3/8	7/8		26.0	6.0
PLB2D02.0128B.31	2DES-2	2	1	350	210	0.95	3	3/8	7/8		30.7	7.5
PLB2D02.0187B.41T	2DES-2	2	1	400	420	1.90	3	3/8	7/8		30.7	7.5
PLB2C03.0138B.41	2CES-3	3	1	400	190	0.50	6	1/2	7/8		37.0	9.1
PLB2C03.0227S.51T	2CES-3	3	1	500	750	1.50	6	1/2	7/8		37.0	9.1
PLB4F03.0138B.41	4FES-3	3	1	400	190	0.50	6	1/2	7/8		44.2	9.5
PLB4F03.0280S.51T	4FES-3	3	1	500	750	1.50	6	1/2	7/8		44.2	9.5
PLB4E04.0227S.51	4EES-4	4	1	500	750	1.50	6	1/2	1-1/8		53.5	12.2
PLB4E04.0337S.51T	4EES-4	4	1	500	750	1.50	6	1/2	1-1/8		53.5	12.2
PLB4D05.0227S.51	4DES-5	5	1	500	750	1.50	6	1/2	1-1/8		62.2	14.5
PLB4D05.0376S.51T	4DES-5	5	1	500	750	1.50	6	1/2	1-1/8		62.2	14.5
PLB4C06.0280S.51	4CES-6	6	1	500	750	1.50	8	5/8	1-1/8		82.4	17.7
PLB4C06.0412S.61T	4CES-6	6	1	630	850	1.80	8	5/8	1-1/8		82.4	17.7
PLB4V07.0337S.51	4VES-7	7	1	500	750	1.50	13	5/8	1-1/8		68.0	16.6
PLB4V07.0412S.61T	4VES-7	7	1	630	850	1.80	13	5/8	1-1/8		68.0	16.6
PLB4T09.0337S.51	4TES-9	9	1	500	750	1.50	13	7/8	1-3/8		81.0	19.9
PLB4T09.0524S.61T	4TES-9	9	1	630	850	1.80	13	7/8	1-3/8		81.0	19.9
PLB4P12.0376S.51	4PES-12	12	1	500	750	1.50	15	7/8	1-3/8		99.0	22.7
PLB4P12.0564S.61T	4PES-12	12	1	630	850	1.80	15	7/8	1-3/8		99.0	22.7
PLB4N14.0412S.61	4NES-14	14	1	630	850	1.80	15	7/8	1-3/8		113.0	26.6
PLB4N14.0653R.52T	4NES-14	14	2	500	1500	3.00	15	7/8	1-3/8		113.0	26.6
PLB4J15.0524S.61	4JE-15	15	1	630	850	1.80	30	7/8	1-5/8		158.0	30.8
PLB4J15.0861R.52T	4JE-15	15	2	500	1500	3.00	30	7/8	1-5/8		158.0	30.8
PLB4H18.0653R.52	4HE-18	18	2	500	1500	3.00	30	7/8	1-5/8		158.0	36.7
PLB4H18.0905R.53T	4HE-18	18	3	500	2250	4.50	30	7/8	1-5/8		158.0	36.7
PLB4G23.0760R.52	4GE-23	23	2	500	1500	3.00	30	7/8	2-1/8		158.0	43.9
PLB4G23.1088R.53T	4GE-23	23	3	500	2250	4.50	30	7/8	2-1/8		158.0	43.9
PLB4F28.0861R.52	4FE-28	28	2	500	1500	3.00	30	7/8	2-1/8		233.0	52.8
PLB4F28.1288R.54T	4FE-28	28	4	500	3000	6.00	30	7/8	2-1/8		233.0	52.8
PLB6J25.0760R.52	6JE-25	25	2	500	1500	3.00	30	7/8	2-1/8		233.0	46.4
PLB6J25.1088R.53T	6JE-25	25	3	500	2250	4.50	30	7/8	2-1/8		233.0	46.4
PLB6H28.0861R.52	6HE-28	28	2	500	1500	3.00	40	7/8	2-1/8		233.0	53.2
PLB6H28.1432R.54T	6HE-28	28	4	500	3000	6.00	40	7/8	2-1/8		233.0	53.2
PLB6G34.1088R.53	6GE-34	34	3	500	2250	4.50	40	1-1/8	2-1/8		233.0	65.5
PLB6G34.1625R.54T	6GE-34	34	4	500	3160	7.40	40	1-1/8	2-1/8	233.0	65.5	
PLB6F44.1288R.54	6FE-44	44	4	500	3000	6.00	55	1-1/8	2-1/8	362.0	83.2	
PLB6F44.2030R.63T	6FE-44	44	3	630	1980	3.90	55	1-1/8	2-1/8	362.0	83.2	
PSB4T05.0337S.51	S4T-5.2Y	5	1	500	750	1.50	15	5/8	1-1/8	39.0	14.0	
PSB4T05.0412S.61T	S4T-5.2Y	5	1	630	850	1.80	15	5/8	1-1/8	39.0	14.0	
PSB4N08.0376S.51	S4N-8.2Y	8	1	500	750	1.50	30	5/8	1-1/8	49.0	17.0	
PSB4N08.0653R.52T	S4N-8.2Y	8	2	500	1500	3.00	30	5/8	1-1/8	49.0	17.0	
PSB4G12.0653R.52	S4G-12.2Y	12	2	500	1500	3.00	30	7/8	1-3/8	69.0	24.0	
PSB4G12.0905R.53T	S4G-12.2Y	12	3	500	2250	4.50	30	7/8	1-3/8	69.0	24.0	
PSB6J16.0861R.52	S6J-16.2Y	16	2	500	1500	3.00	30	7/8	1-5/8	81.0	31.0	
PSB6J16.1158R.53T	S6J-16.2Y	16	3	500	2250	4.50	30	7/8	1-5/8	81.0	31.0	
PSB6H20.0905R.53	S6H-20.2Y	20	3	500	2250	4.50	30	7/8	1-5/8	97.0	37.0	
PSB6H20.1432R.54T	S6H-20.2Y	20	4	500	3000	6.00	30	7/8	1-5/8	97.0	37.0	
PSB6G25.1088R.53	S6G-25.2Y	25	3	500	2250	4.50	40	7/8	1-5/8	116.0	45.0	
PSB6G25.1625R.54T	S6G-25.2Y	25	4	500	3160	7.40	40	7/8	1-5/8	116.0	45.0	
PSB6F30.1288R.54	S6F-30.2Y	30	4	500	3000	6.00	40	1-1/8	1-5/8	135.0	53.0	
PSB6F30.1890R.63T	S6F-30.2Y	30	3	630	1980	3.90	40	1-1/8	1-5/8	135.0	53.0	

All 300mm and 350mm Fan Motor models are 230V/1Ph/50Hz and all others are 400V/3Ph/50Hz
Condensers are remote

Dimensions

Model	Size (mm)								*Weight
	A	B	H	W	L	H*	W*	L*	(kg)
PMB2KA5.0054B.21	500	860	510	900	700	675	1050	850	78
PMB2KA5.0090B.31T	570	960	515	1000	770	680	1150	920	79
PMB2JA7.0090B.31	570	960	515	1000	770	680	1150	920	79
PMB2JA7.0110B.31T	570	960	515	1000	770	680	1150	920	84
PMB2H02.0090B.31	570	960	515	1000	770	680	1150	920	88
PMB2H02.0128B.31T	570	960	515	1000	770	680	1150	920	89
PMB2G02.0110B.31	570	960	515	1000	770	680	1150	920	88
PMB2G02.0138B.41T	650	1060	560	1100	850	725	1250	1000	89
PMB2F03.0128B.31	570	960	515	1000	770	680	1150	920	95
PMB2F03.0187B.41T	650	1060	560	1100	850	725	1250	1000	96
PMB2E03.0187B.41	650	1060	560	1100	850	725	1250	1000	125
PMB2E03.0227S.51T	1080	860	745	900	1280	910	1050	1430	131
PMB2D03.0227S.51	1080	860	745	900	1280	910	1050	1430	128
PMB2D03.0280S.51T	1080	860	745	900	1280	910	1050	1430	131
PMB2C04.0280S.51	1080	860	745	900	1280	910	1050	1430	130
PMB2C04.0337S.51T	1080	860	745	900	1280	910	1050	1430	173
PMB4F05.0280S.51	1080	860	745	900	1280	910	1050	1430	150
PMB4F05.0376S.51T	1080	860	745	900	1280	910	1050	1430	193
PMB4E06.0337S.51	1080	860	745	900	1280	910	1050	1430	193
PMB4E06.0466S.61T	1280	1040	950	1080	1480	1115	1230	1630	199
PMB4D07.0412S.61	1280	1040	950	1080	1480	1115	1230	1630	206
PMB4D07.0564S.61T	1280	1040	950	1080	1480	1115	1230	1630	224
PMB4C09.0524S.61	1280	1040	950	1080	1480	1115	1230	1630	215
PMB4C09.0760R.52T	1080	760	900	800	1280	1065	950	1430	241
PMB4V10.0524S.61	1280	1040	950	1080	1480	1115	1230	1630	299
PMB4V10.0760R.52T	1080	760	900	800	1280	1065	950	1430	306
PMB4T12.0653R.52	1080	760	900	800	1280	1065	950	1430	304
PMB4T12.0861R.52T	1080	760	900	800	1280	1065	950	1430	422
PMB4P15.0760R.52	1080	760	900	800	1280	1065	950	1430	331
PMB4P15.1038R.53T	1080	760	900	800	1280	1065	950	1430	458
PMB4N20.0861R.52	1080	760	900	800	1280	1065	950	1430	446
PMB4N20.1158R.53T	1080	760	900	800	1280	1065	950	1430	479
PMB4J22.1038R.53	1080	760	900	800	1280	1065	950	1430	510
PMB4J22.1288R.54T	1080	760	900	800	1280	1065	950	1430	569
PMB4H25.1088R.53	1080	760	900	800	1280	1065	950	1430	532
PMB4H25.1540R.54T	1080	760	900	800	1280	1065	950	1430	598
PMB4G30.1260R.53	1080	760	900	800	1280	1065	950	1430	616
PMB4G30.1707R.53T	1080	760	900	800	1280	1065	950	1430	662
PMB4F35.1540R.54	1080	760	900	800	1280	1065	950	1430	670
PMB4F35.2030R.63T	1080	760	900	800	1280	1065	950	1430	768
PMB6J33.1385R.54	1080	760	900	800	1280	1065	950	1430	674
PMB6J33.1890R.63T	1080	760	900	800	1280	1065	950	1430	767
PMB6H35.1625R.54	1080	760	900	800	1280	1065	950	1430	772
PMB6H35.2254R.64T	1080	760	900	800	1280	1065	950	1430	832
PMB6G40.1890R.63	1780	860	1050	900	1980	1215	1050	2130	816
PMB6G40.2500R.64T	1780	860	1050	900	1980	1215	1050	2130	934
PMB6F50.2254R.64	1780	860	1050	900	1980	1215	1050	2130	898
PMB6G60.2650R.64	1780	860	1050	900	1980	1215	1050	2130	1219
PLB2KA5.0054B.21	550	1060	510	1100	750	675	1250	900	82
PLB2KA5.0064B.21T	550	1060	510	1100	750	675	1250	900	83
PLB2JA7.0054B.21	550	1060	510	1100	750	675	1250	900	82
PLB2JA7.0064B.21T	550	1060	510	1100	750	675	1250	900	83
PLB2H01.0054B.21	550	1060	510	1100	750	675	1250	900	83
PLB2H01.0090B.31T	600	1060	545	1100	800	710	1250	950	85
PLB2G02.0064B.21	550	1060	510	1100	750	675	1250	900	85
PLB2G02.0110B.31T	600	1060	545	1100	800	710	1250	950	90
PLB2F02.0090B.31	600	1060	545	1100	800	710	1250	950	87
PLB2F02.0128B.31T	600	1060	545	1100	800	710	1250	950	93

Condensers are remote

Dimensions

Model	Size (mm)								*Weight
	A	B	H	W	L	H*	W*	L*	(kg)
PLB2E02.0110B.31	600	1060	545	1100	800	710	1250	950	119
PLB2E02.0138B.41T	650	1060	560	1100	850	725	1250	1000	121
PLB2D02.0128B.31	600	1060	545	1100	800	710	1250	950	121
PLB2D02.0187B.41T	1250	1060	545	1100	1450	710	1250	1600	124
PLB2C03.0138B.41	650	1060	560	1100	850	725	1250	1000	128
PLB2C03.0227S.51T	1080	860	750	900	1280	915	1050	1430	134
PLB4F03.0138B.41	650	1060	560	1100	850	725	1250	1000	143
PLB4F03.0280S.51T	1080	860	750	900	1280	915	1050	1430	149
PLB4E04.0227S.51	1080	860	750	900	1280	915	1050	1430	155
PLB4E04.0337S.51T	1080	860	750	900	1280	915	1050	1430	198
PLB4D05.0227S.51	1080	860	750	900	1280	915	1050	1430	157
PLB4D05.0376S.51T	1080	860	750	900	1280	915	1050	1430	207
PLB4C06.0280S.51	1080	860	750	900	1280	915	1050	1430	204
PLB4C06.0412S.61T	1280	1040	950	1080	1480	1115	1230	1630	214
PLB4V07.0337S.51	1080	860	750	900	1280	915	1050	1430	258
PLB4V07.0412S.61T	1280	1040	950	1080	1480	1115	1230	1630	264
PLB4T09.0337S.51	1080	860	750	900	1280	915	1050	1430	267
PLB4T09.0524S.61T	1280	1040	950	1080	1480	1115	1230	1630	290
PLB4P12.0376S.51	1080	860	750	900	1280	915	1050	1430	282
PLB4P12.0564S.61T	1280	1040	950	1080	1480	1115	1230	1630	313
PLB4N14.0412S.61	1280	1040	950	1080	1480	1115	1230	1630	289
PLB4N14.0653R.52T	1080	760	900	800	1280	1065	950	1430	330
PLB4J15.0524S.61	1280	1040	950	1080	1480	1115	1230	1630	388
PLB4J15.0861R.52T	1080	760	900	800	1280	1065	950	1430	507
PLB4H18.0653R.52	1080	760	900	800	1280	1065	950	1430	395
PLB4H18.0905R.53T	1080	760	900	800	1280	1065	950	1430	539
PLB4G23.0760R.52	1080	760	900	800	1280	1065	950	1430	528
PLB4G23.1088R.53T	1080	760	900	800	1280	1065	950	1430	626
PLB4F28.0861R.52	1080	760	900	800	1280	1065	950	1430	562
PLB4F28.1288R.54T	1080	760	900	800	1280	1065	950	1430	667
PLB6J25.0760R.52	1080	760	900	800	1280	1065	950	1430	571
PLB6J25.1088R.53T	1080	760	900	800	1280	1065	950	1430	670
PLB6H28.0861R.52	1080	760	900	800	1280	1065	950	1430	596
PLB6H28.1432R.54T	1080	760	900	800	1280	1065	950	1430	728
PLB6G34.1088R.53	1080	760	900	800	1280	1065	950	1430	679
PLB6G34.1625R.54T	1080	760	900	800	1280	1065	950	1430	824
PLB6F44.1288R.54	1080	760	900	800	1280	1065	950	1430	728
PLB6F44.2030R.63T	1080	760	900	800	1280	1065	950	1430	706
PSB4T05.0337S.51	1080	860	750	900	1280	915	1050	1430	281
PSB4T05.0412S.61T	1280	1040	950	1080	1480	1115	1230	1630	299
PSB4N08.0376S.51	1080	860	750	900	1280	915	1050	1430	314
PSB4N08.0653R.52T	1080	860	950	900	1280	1115	1050	1430	407
PSB4G12.0653R.52	1080	860	950	900	1280	1115	1050	1430	460
PSB4G12.0905R.53T	1080	860	950	900	1280	1115	1050	1430	474
PSB6J16.0861R.52	1080	860	950	900	1280	1115	1050	1430	500
PSB6J16.1158R.53T	1080	860	950	900	1280	1115	1050	1430	539
PSB6H20.0905R.53	1080	860	950	900	1280	1115	1050	1430	534
PSB6H20.1432R.54T	1080	860	950	900	1280	1115	1050	1430	591
PSB6G25.1088R.53	1080	860	950	900	1280	1115	1050	1430	607
PSB6G25.1625R.54T	1080	860	950	900	1280	1115	1050	1430	632
PSB6F30.1288R.54	1080	860	950	900	1280	1115	1050	1430	635
PSB6F30.1890R.63T	1080	860	950	900	1280	1115	1050	1430	668

Condensers are remote

Dimensions

CAD Drawings

Base Frame comes with 300mm, 350mm, 400mm Fan Motors

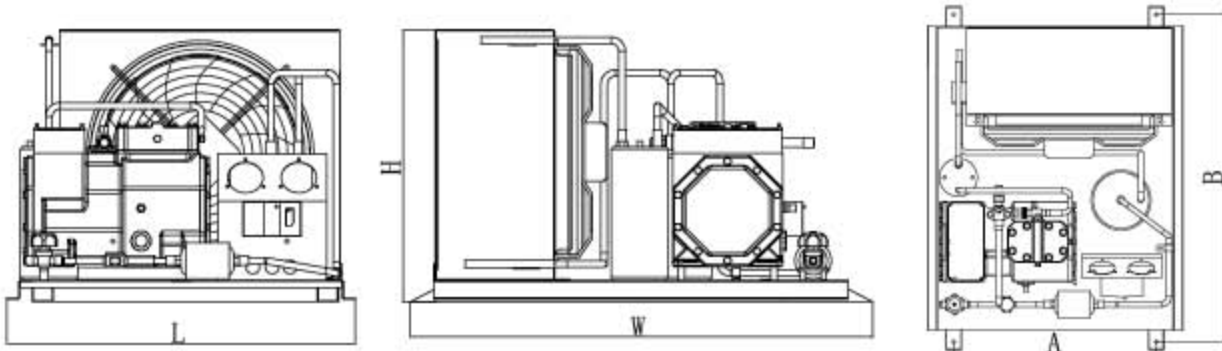

Skid Frame comes with 500mm, 630mm Single Fan Motors

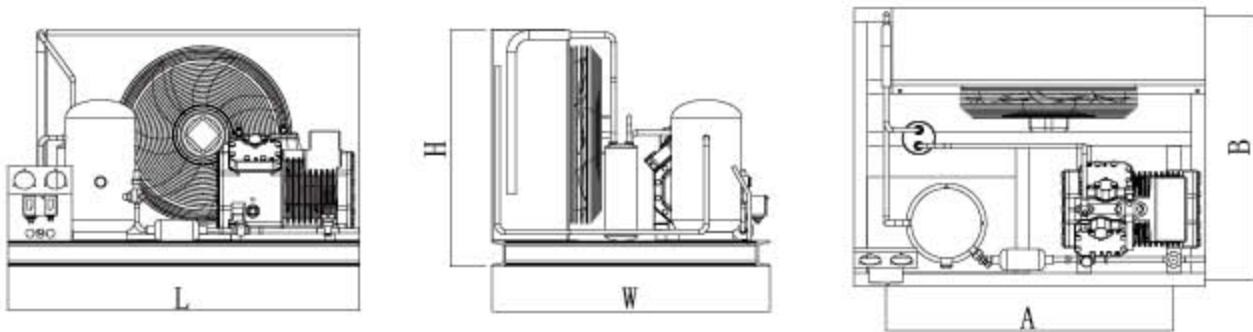

Skid Frame comes with Remote Condensers

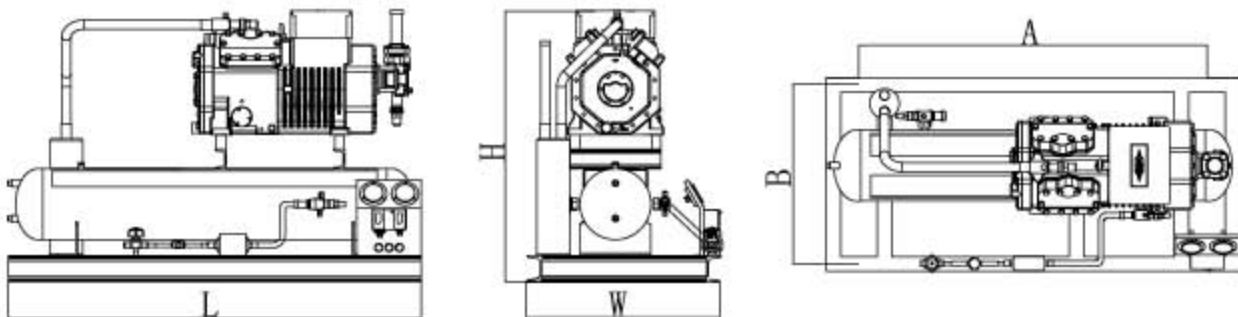

Accessories chart

Model	Medium Temperature Series		Low Temperature Series		
	PMB2KA5.0054B.21... PMB2E03.0187B.41	PMB2E03.0227S.51T... PMB8G60.2650R.64	PLB2KA5.0054B.21... PLB4F03.0138B.41	PLB2C03.0227S.51T... PLB6F44.2030R.63T	PSB4T05.0337S.51... PSB6F30.1890R.63T
Frame Structure					
Skid Frame	-	Standard	-	Standard	Standard
Base Frame	Standard	-	Standard	-	-
Powder Coating	Optional	Optional	Optional	Optional	Optional
Extra Bracket(Remote Condenser)	-	Optional (PMB4C09.0760R.52T- PMB8G60.2650R.64)	-	Optional (PLB4N14.0653R.52T- PLB6F44.2030R.63T)	Optional (PSB4N08.0653R.52T- PSB6F30.1890R.63T)
Compressor					
Compressor Head Fan	Optional	Optional	Optional	Optional	Optional
CIC	-	-	Optional	Optional	-
Compressor Capacity Regulator	Optional	Optional (PMB4F05.0280S.51- PMB6F50.2254R.64)	Optional (PLB4F03.0138B.41)	Optional (PLB4F03.0280S.51T- PLB6F44.2030R.63T)	Optional
Start Unloader	-	Optional (PMB4V10.0524S.61- PMB6F50.2254R.64)	-	Optional (PLB4V07.0337S.51- PLB6F44.2030R.63T)	-
Oil System					
Oil Separator	Standard	Standard	Standard	Standard	Standard
Crankcase Heater	Standard	Standard	Standard	Standard	Standard
Discharge Assembly					
Vibration Eliminator	Optional	Optional	Optional	Optional	Optional
Muffler	Optional (PMB2F03.0128B.31- PMB2E03.0187B.41)	Optional	Optional (PLB2E02.0110B.31- PLB4F03.0138B.41)	Optional	Optional
Discharge Check Valve	Optional	Optional	Optional	Optional	Optional
Liquid Assembly					
Liquid Receiver	Standard	Standard	Standard	Standard	Standard
Ball Valve	Standard	Standard	Standard	Standard	Standard
Liquid Line Filter Drier	Standard	Standard	Standard	Standard	Standard
Moisture Indicator	Standard	Standard	Standard	Standard	Standard
Liquid Solenoid Valve	Optional	Optional	Optional	Optional	Optional
Suction Assembly					
Vibration Eliminator	Optional	Optional	Optional	Optional	Optional
Suction Accumulator	-	-	Standard	Standard	Standard
Insulation	-	-	Standard	Standard	Standard
Suction Strainer	Optional	Optional	Optional	Optional	Optional

Accessories chart

Model	Medium Temperature Series		Low Temperature Series		
	PMB2KA5.0054B.21... PMB2E03.0187B.41	PMB2E03.0227S.51T... PMB8G60.2650R.64	PLB2KA5.0054B.21... PLB4F03.0138B.41	PLB2C03.0227S.51T... PLB6F44.2030R.63T	PSB4T05.0337S.51... PSB6F30.1890R.63T
Safety Controls					
High & Low Glycerine filled gauges	Standard	Standard	Standard	Standard	Standard
OLC Oil Level Switch	-	Optional (PMB4V10.0524S.61- PMB8G60.2650R.64)	-	Optional (PLB4V07.0337S.51- PLB4N14.0653R.52T)	Optional
Oil Pressure Differential Switch MP54	-	Optional (PMB4J22.1038R.53- PMB8G60.2650R.64)	-	Optional (PLB4J15.0524S.61- PLB6F44.2030R.63T)	Optional
Electronic Oil Level Switch Delta-P11	Optional	Standard (PMB4J22.1038R.53- PMB8G60.2650R.64) Optional (PMB2E03.0227S.51T- PMB4N20.1158R.53T)	Optional	Standard (PLB4J15.0524S.61- PLB6F44.2030R.63T) Optional (PLB2C03.0227S.51T- PLB4N14.0653R.52T)	Standard
Glycerine Filled Oil Pressure Gauge	-	Optional	-	Optional	Optional
Dual Pressure Controls & Thermocouples Hoses	Standard	Standard	Standard	Standard	Standard
Subcooling System					
Liquid Subcooling including Filter ,Sight Glass, Solenoid Valve	-	-	-	-	Standard
TXV	-	-	-	-	Standard
CIC	-	-	-	-	Optional
Energy Saving Option					
EC Fan	Optional	Optional (PMB2E03.0227S.51T- PMB4T12.0861R.52T)	Optional	Optional (PLB2C03.0227S.51T- PLB4H18.0905R.53T)	Optional (PSB4T05.0337S.51- PSB4G12.0905R.53T)
Condenser Fan Speed Control	Optional	Optional	Optional	Optional	Optional
Electronical Option					
Electronical Control Box	Optional	Optional	Optional	Optional	Optional
Compressor Strat-up Control	Optional	Optional	Optional	Optional	Optional

Addition Options

Polapak provides addition options

- (a) Motor Special Voltage
- (b) Corrosion Protection Fins for condensers
 - Blue Fins
 - Epoxy Fins
- (c) Weather Protection Housing





Visit Us:

www.edensolution.com

Eden accepts no responsibility for possible errors in catalogues, brochures and other printed materials. Eden reserves the right to alter its products without notice. This includes products that have been ordered and such alterations can be made without prior notice.

